

This file is available for free download at <http://www.iluvmyrx7.com>

This file was not scanned to deprive Mazda of any money - it was scanned due to the rareness of the original manuals and the overwhelming need of the RX-7 owner to have this information so that they can accurately troubleshoot problems. Perhaps if Mazda's dealerships could support the Rotary Engine it wouldn't be so necessary for the owners to do so.



Many thanks to Lenny Terris for scanning this.

Before beginning any service procedure, refer to the 1994 RX-7 Body Electrical Troubleshooting Manual; see section S for air bag system service warnings and section J1 for audio antitheft system alarm conditions.

G

ENGINE ELECTRICAL SYSTEM

INDEX	G - 2
OUTLINE	G - 3
SPECIFICATIONS	G - 3
TROUBLESHOOTING GUIDE	G - 4
DIAGNOSTIC INDEX	G - 4
SYMPTOM TROUBLESHOOTING	G - 4
CHARGING SYSTEM	G - 7
PREPARATION	G - 7
CIRCUIT DIAGRAM	G - 7
TROUBLESHOOTING	G - 8
BATTERY	G - 9
ALTERNATOR	G -12
DRIVE BELT	G -15
IGNITION SYSTEM	G -16
PREPARATION	G -16
CIRCUIT DIAGRAM	G -16
IGNITION TIMING	G -17
SPARK PLUGS	G -18
IGNITION COIL	G -20
HIGH-TENSION LEAD	G -21
IGNITER	G -22
STARTING SYSTEM	G -24
PREPARATION	G -24
CIRCUIT DIAGRAM	G -24
STARTER	G -24
INTERLOCK SWITCH	G -32

G

INDEX

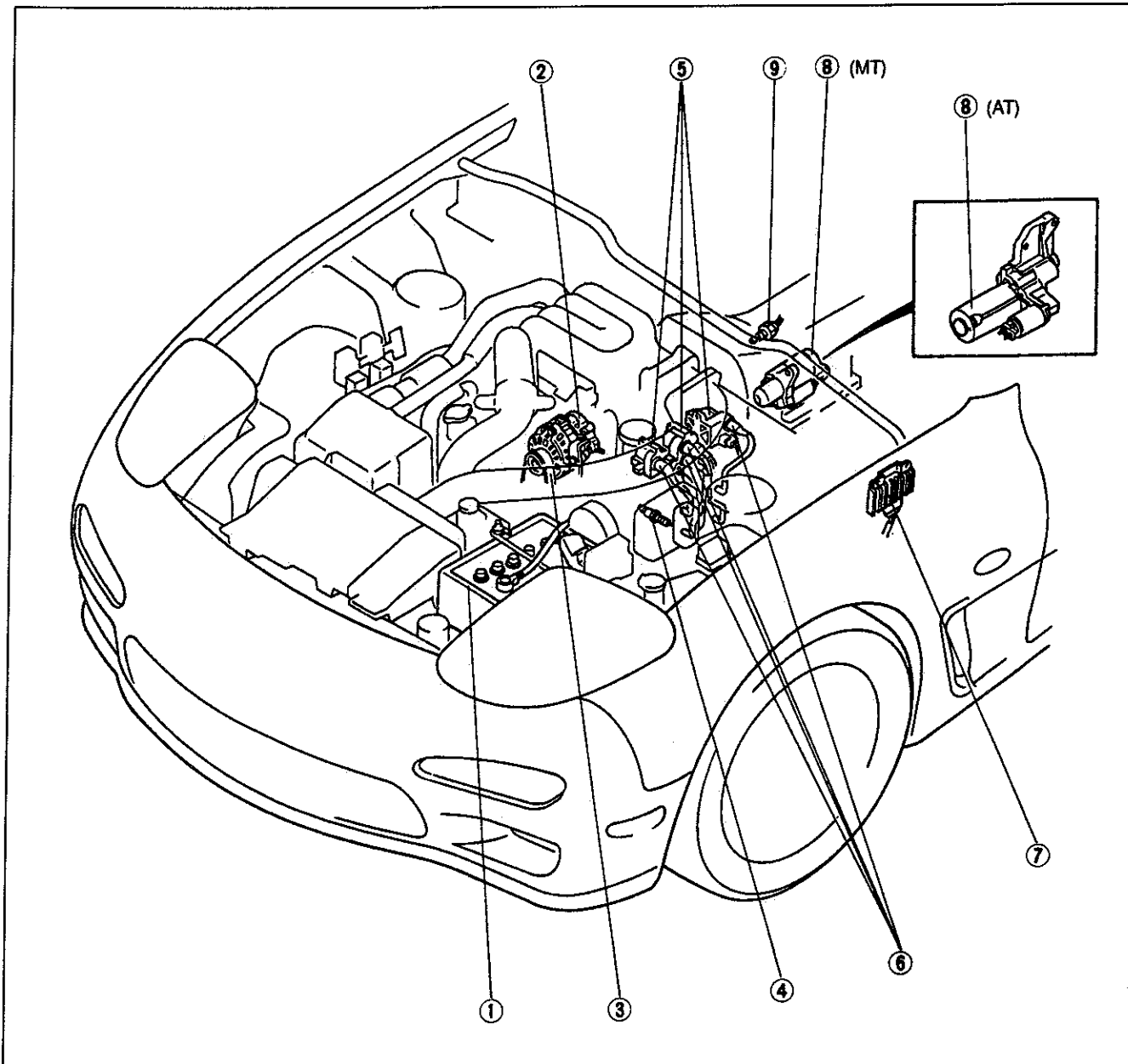

- 1. Battery
 - Removal / Installation page G- 9
 - Inspection page G- 9
 - Recharging ... page G-10
- 2. Alternator
 - Removal / Installation page G-12
 - Disassembly / Assembly page G-13
 - Inspection page G-14
- 3. Drive belt
 - Inspection page G-15
 - Adjustment ... page G-15

- 4. Spark plug
 - Removal / Installation page G-18
 - Spark test page G-18
 - Inspection page G-19
- 5. Ignition coil
 - Removal / Installation page G-20
 - Inspection page G-21
- 6. High-tension leads
 - Removal / Installation page G-21
 - Inspection page G-21
- 7. Igniter
 - Removal / Installation page G-22
 - Inspection page G-23

- 8. Stator
 - Inspection (On-Vehicle) page G-24
 - Removal / Installation page G-25
 - Performance inspection page G-27
 - Disassembly / Assembly page G-28
 - Inspection page G-30
- 9. Interlock switch
 - Inspection page G-32

OUTLINE

SPECIFICATIONS

Item		Transmission		MT	AT	
Battery	Voltage	V		12, negative ground		
	Type and Capacity (5-hour rate)			65D23L (43Ah)	75D26L (52Ah)	
Dark current* ¹		mA		20 or less		
Ignition system	Spark timing (TEN terminal grounded)		Leading : ATDC 5° (BTDC -5°) Trailing : ATDC 20° (BTDC -20°) at idle (AT: P range)			
	Spark advance		Electronic spark advance (ESA)			
	Spark plug	Type	Leading	NGK : BUR7EQP* ² , BUR6EQP, BUR7EQ, BUR6EQ		
			Trailing	NGK : BUR9EQ* ² , BUR8EQP, BUR9EQP, BUR8EQ		
	Plug gap	mm {in}	1.1-1.7 {0.044-0.066}			
Alternator	Output	V-A		12-100		
	Regulated voltage	V		14.1-14.7 (with temperature gradient characteristics)		
	Brush length	Standard	mm {in}	21.5 {0.846}		
Minimum		mm {in}	8.0 {0.32}			
Stator	Type			Direct	Reduction	
	Output	V-KW		12-1.2	12-2.0	
	Output (no load)	Voltage	V		11	
		Current	A		Max 90	
		Speed	rpm		Min 3000	Min 2200
	Brush length	Standard	mm {in}	17.5 {0.689}	18 {0.71}	
Minimum		mm {in}	12 {0.47}	11{0.43}		

*¹ Dark current is the constant flow of current while the ignition is OFF (i.e., audio unit, clock, etc)

*² Standard plug

TROUBLESHOOTING GUIDE

DIAGNOSTIC INDEX

No.	Troubleshooting items	Page
1	Will not crank-starter motor does not operate	Below
2	Will not crank-starter motor spins	Below
3	Cranks slowly	G-5
4	Alternator warning light illuminates while engine running	G-5
5	Discharged battery	G-5
6	Misfire	G-6

SYMPTOM TROUBLESHOOTING

B+: Battery positive voltage

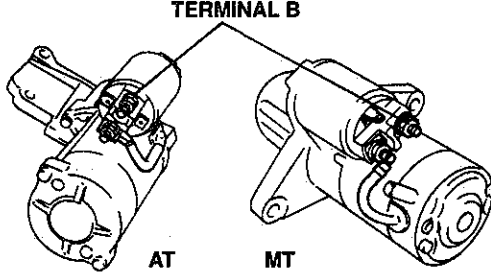
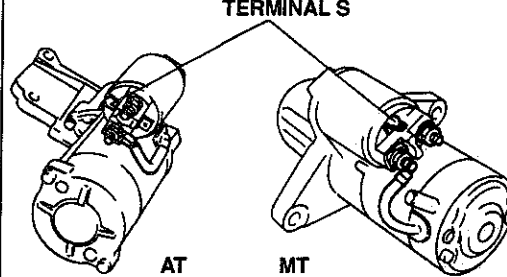
1		Will not crank-starter motor does not operate	
STEP	INSPECTION	ACTION	
1	Does engine crank with fully charged battery?	Yes	Check charging system ☞ page G-8
		No	Go to next step
2	Is B+ present at terminal B? TERMINAL B 	Yes	Go to next step
		No	Check wiring harness
3	Is B+ present at terminal S with ignition switch in START position? TERMINAL S 	Yes	<ul style="list-style-type: none"> • Check magnetic switch • Check armature ☞ page G-30 ☞ page G-30
		No	<ul style="list-style-type: none"> • Check park/neutral switch • Check ignition switch • Check wiring harness ☞ Section K ☞ 1994 RX-7 Body Electrical Troubleshooting Manual Section Z4

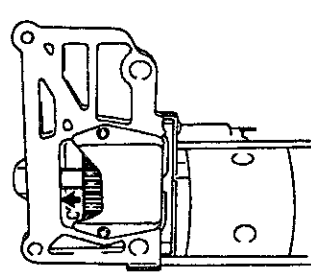
2		Will not crank-starter motor spins	
STEP	INSPECTION	ACTION	
1	Is drive pinion pushed out when energized? (Is click heard?) 	Yes	Remove starter and check ring gear teeth and starter drive pinion teeth
		No	Check magnetic switch ☞ page G-30

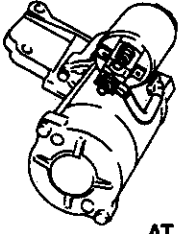
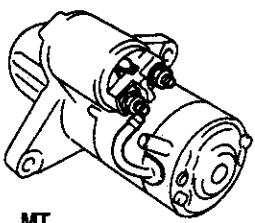
3		Crank slowly	
STEP	INSPECTION	ACTION	
1	Does engine crank normally with fully charged battery?	Yes	Check charging system ↔ page G-8
		No	Go to next step
2	Are starter cable connections loose or corroded? <div style="display: flex; justify-content: space-around; align-items: center;">   </div> <p style="text-align: center; margin-top: 5px;">AT MT</p>	Yes	Repair connection
		No	Check starter for binding (brush, armature, etc.) ↔ page G-30

G

B+ : Battery Positive Voltage

4		Alternator warning light illuminates while engine running	
STEP	INSPECTION	ACTION	
1	Is B+ correct at idle? Specification: 14.1-14.7V	Yes	Check wiring harness (Alternator terminal L-Alternator warning light)
		No	Check charging system ↔ page G-8

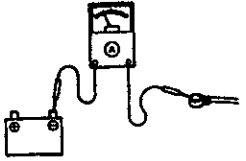
5		Discharged battery	
STEP	INSPECTION	ACTION	
1	Is charging system OK? ↔ page G-8	Yes	Turn ignition switch OFF and measure dark current as shown <div style="text-align: center;">  </div> <p style="text-align: center; margin-top: 5px;">Dark current: 20 mA max</p>
		No	Repair or replace parts as necessary

B+: Battery positive voltage

6		Misfire	
STEP	INSPECTION	ACTION	
1	Are "02" or "03" displayed on SST while ignition switch ON?	Yes	Check for cause ☞ Section F
		No	Go to next step
2	Are connector and wiring harness connections OK? (High-tension leads, igniter, ignition coils, PCME)	Yes	Go to next step
		No	Repair connection
3	Remove each High-tension lead; is there strong blue spark while engine is cranking?	Yes	Go to step 10
		No	Go to next step
4	Is resistance of High-tension leads OK? Specification: 16 kΩ per 1m (3.28 ft) (at 20°C [68°F])	Yes	Go to next step
		No	Replace High-tension lead(s)
5	Is there B+ at ignition coils terminal A and igniter terminal D with ignition switch in ON position? (Disconnect each connection) ☞ page G-16	Yes	Go to next step
		No	Check wiring harness (ignition coils terminal A, igniter terminal D-ignition switch) ☞ Page G-16
6	Are ignition coils OK? ☞ page G-21	Yes	Go to next step
		No	Replace ignition coil ☞ page G-20
7	Is wiring harness from ignition coils to igniter OK? ☞ page G-16	Yes	Go to next step
		No	Repair or replace
8	Is igniter OK? ☞ page G-23	Yes	Go to next step
		No	Replace igniter ☞ page G-22
9	Is wiring harness from igniter to PCME terminals OK? ☞ page G-16	Yes	Go to next step
		No	Repair or replace
10	Is input sensor OK? ● Crankshaft position sensor ● Manifold absolute pressure sensor ☞ Section F	Yes	Replace PCME ☞ page F-150
		No	Check input sensor

CHARGING SYSTEM

PREPARATION
SST

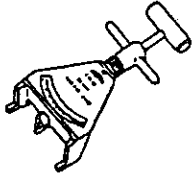
<p>49 9200 020 Tension gauge V-ribbed belt</p>		<p>For inspection of drive belt tension</p>
--	---	---

CIRCUIT DIAGRAM

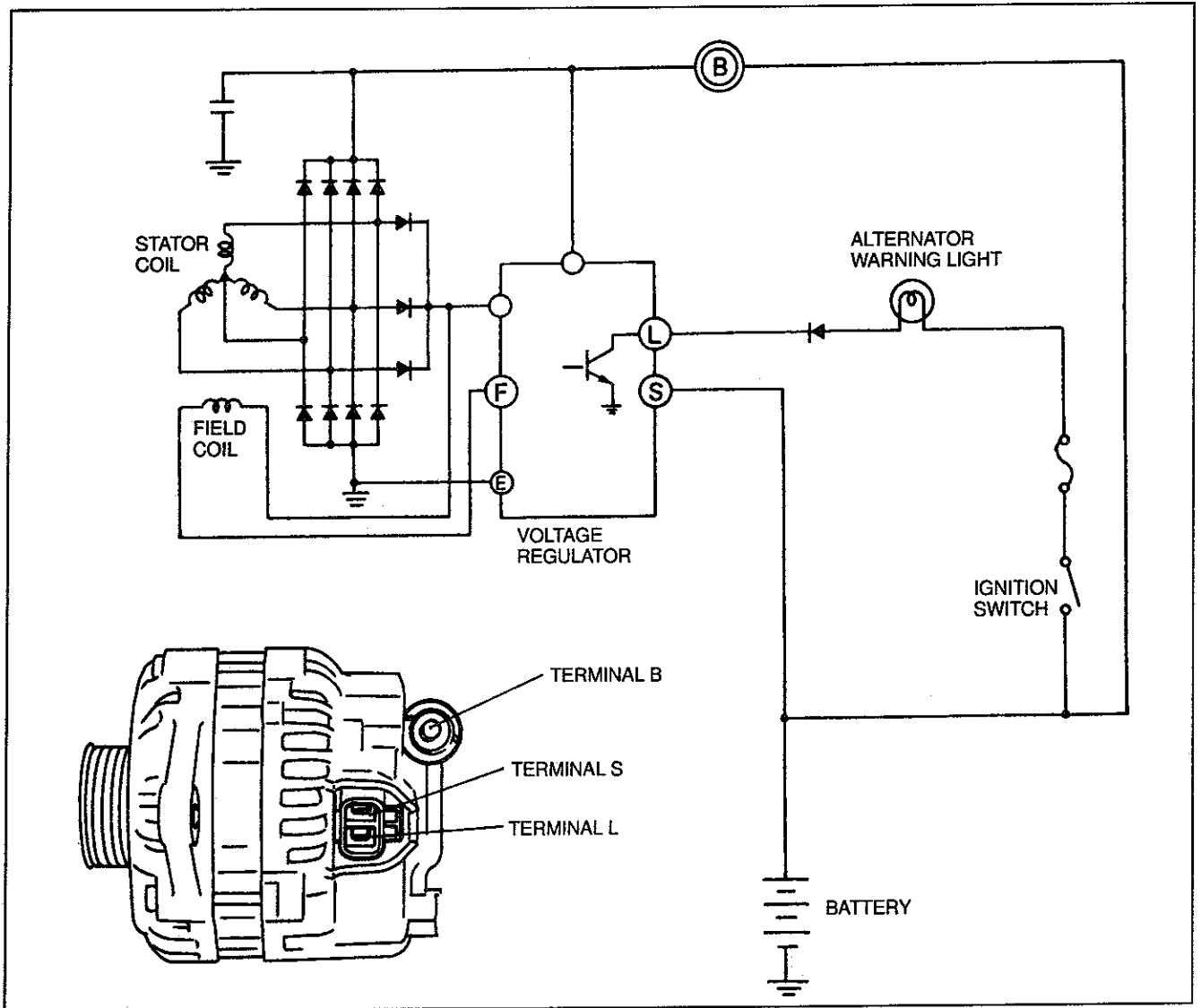

The alternator has a self-diagnosis function to warn of the following problems in the charging system. If a problem arises, the alternator warning light illuminates.

1. Terminal S circuit open
2. No voltage output
3. Field coil circuit open
4. Terminal B circuit open
5. Voltage output too high (above 16.2V)

TROUBLESHOOTING

B+: Battery positive voltage

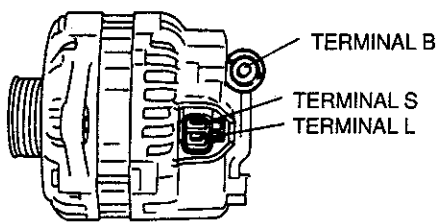
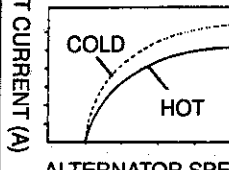
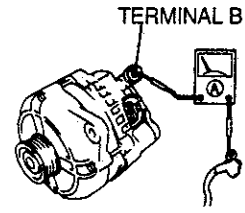
STEP	INSPECTION	ACTION													
1	Check battery positive voltage, is it correct? Specification: Above 12.4V	Yes	Go to next step												
		No	Check battery ☞ page G-9												
2	Does alternator warning light illuminate with ignition switch ON?	Yes	Go to next step												
		No	Check warning light bulb and wiring harness (Alternator warning light-Terminal L)												
3	Does alternator warning light go out after engine started?	Yes	Go to step 5												
		No	Go to next step												
4	Is voltage at alternator terminals correct? Specification: <table border="1" style="margin-left: 20px;"> <thead> <tr> <th>Terminal</th> <th>Ign: ON (V)</th> <th>Idle (V)</th> </tr> </thead> <tbody> <tr> <td>B</td> <td>B+</td> <td>14.1-14.7</td> </tr> <tr> <td>L</td> <td>Approx. 1</td> <td>12.9-13.5</td> </tr> <tr> <td>S</td> <td>B+</td> <td>14.1-14.7</td> </tr> </tbody> </table> 	Terminal	Ign: ON (V)	Idle (V)	B	B+	14.1-14.7	L	Approx. 1	12.9-13.5	S	B+	14.1-14.7	Yes	Check wiring harness (Battery-Terminal L)
		Terminal	Ign: ON (V)	Idle (V)											
B	B+	14.1-14.7													
L	Approx. 1	12.9-13.5													
S	B+	14.1-14.7													
No	<ul style="list-style-type: none"> Check and repair wiring harness as necessary ☞ page G-12 Replace or repair alternator 														
5	1. Connect ammeter (100A min.) between terminal B and harness 2. Start engine 3. Turn all electrical loads ON and depress brake pedal 4. Is output current 100A or more at 2,500-3,000 rpm? Caution <ul style="list-style-type: none"> Do not ground terminal B  	Yes	Charging system normal												
		No	Go to next step												
6	Is drive belt tension OK? ☞ page G-15	Yes	Replace or repair alternator ☞ page G-12												
		No	<ul style="list-style-type: none"> Adjust drive belt tension ☞ page G-15 Replace drive belt 												

BATTERY

Removal / Installation

1. Remove in the order shown in the figure.
2. Install in the reverse order of removal.

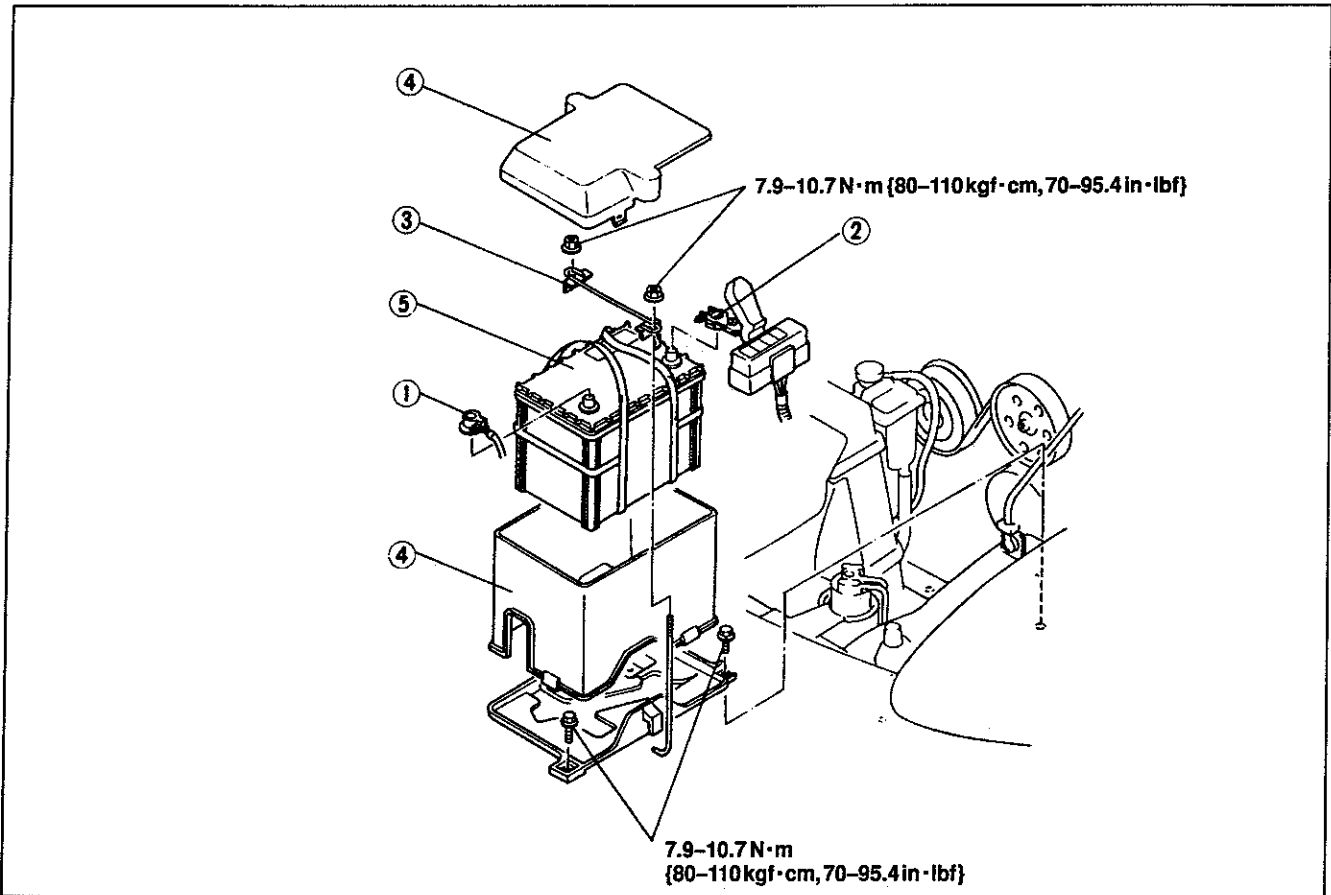

1. Battery negative cable
2. Battery positive cable

3. Battery clamp
4. Battery box

5. Battery
 Inspection page G- 9
 Recharging page G-10

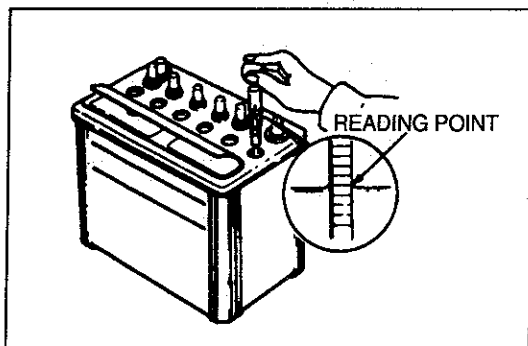
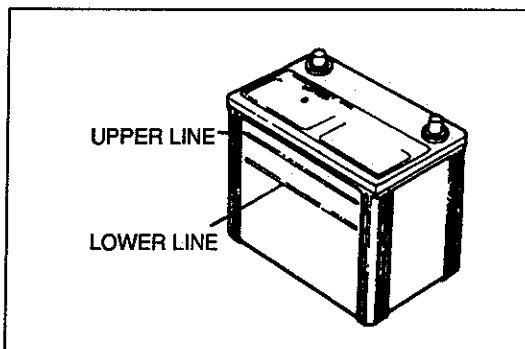

Inspection
Electrolyte level

Warning

- Hydrogen gas is produced during normal battery operation. A battery-related explosion can cause serious injury. Keep all flames (including cigarettes), heat, and sparks away from the top and surrounding area of open battery cells.

Caution

- To prevent damage to electrical components or the battery, turn all accessories off and stop the engine before performing maintenance or recharging the battery.

Caution

- When disconnecting the battery, remove the negative cable first and install it last to prevent damage to electrical components or the battery.

Electrolyte level and specific gravity

1. Verify that the electrolyte level is between the "Upper" and "Lower" level marks.
2. Add distilled water if necessary, but do not over fill.
3. Check the specific gravity with a hydrometer.
Specific Gravity: 1.27-1.29 (at 20°C {68°F})

Battery Discharge Test

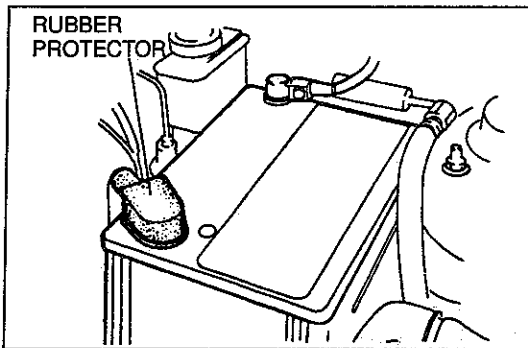
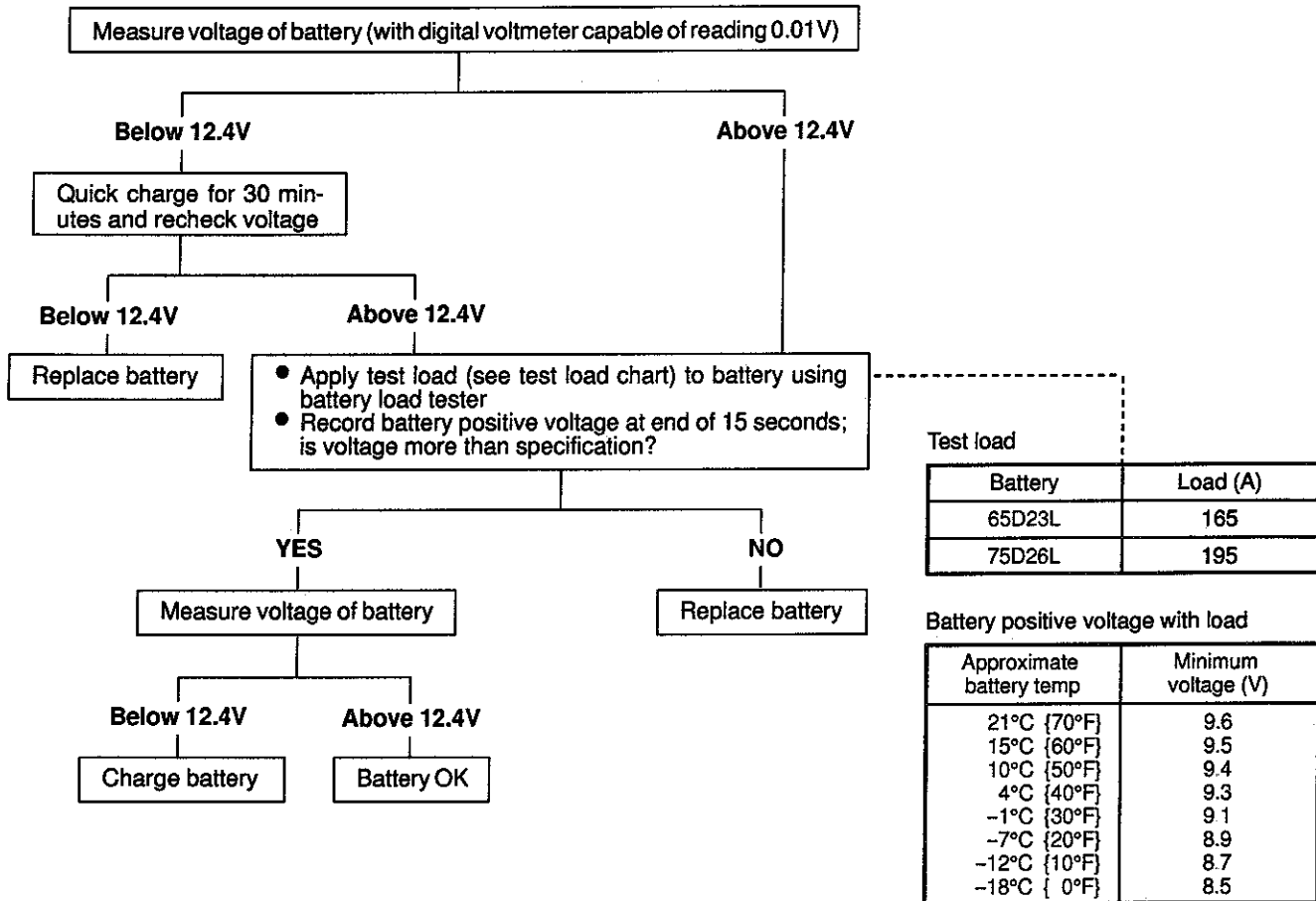

Terminal and cable

1. Remove any corrosion on the clamps or battery posts, and coat them with grease.
2. Verify that the battery top is clean. If necessary, clean with baking soda and water.
3. Verify that cables are not frayed or corroded. Repair or replace if necessary.
4. Verify that cable clamps are tight.
5. Verify that the rubber protector completely covers the positive terminal and clamp.

Recharging

Battery	Slow charge (A)	Quick charge (A)
65D23L	Under 5	Max. 25
75D26L	Under 8	Max. 30

Slow charging

It is not necessary to remove the vent caps to perform a slow charge.

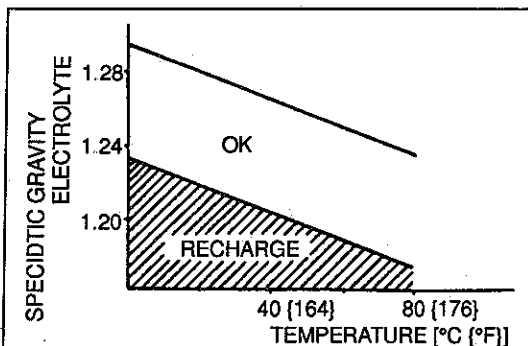

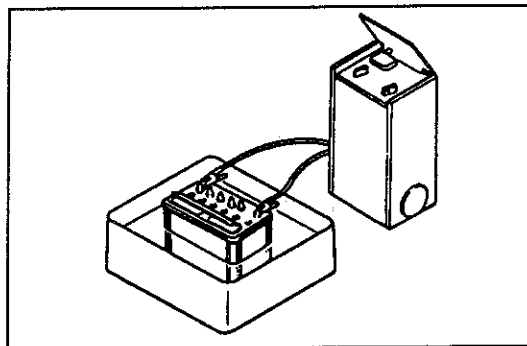

Quick charging

1. Remove the battery from the vehicle and remove the vent caps to perform a quick charge.

Caution

- Obtain the code number and deactivate the audio anti-theft system before disconnecting the battery. (Refer to the 1994 RX-7 Body Electrical Troubleshooting Manual section J1)

Caution

- To avoid damaging the battery, do not quick charge for over 30 minutes.

2. Place the battery in a pan of water to prevent it from overheating, but keep water away from the top of the battery.

ALTERNATOR

Caution

- Reversing the battery connections or using high-voltage testers will damage the rectifier.

Caution

- Do not start the engine while the connector is disconnected from terminals L and S. It can damage the alternator.

Note

- Positive voltage is always present at alternator terminal B.

Removal / Installation

1. Remove in the order shown in the figure.
2. Install in the reverse order of removal.

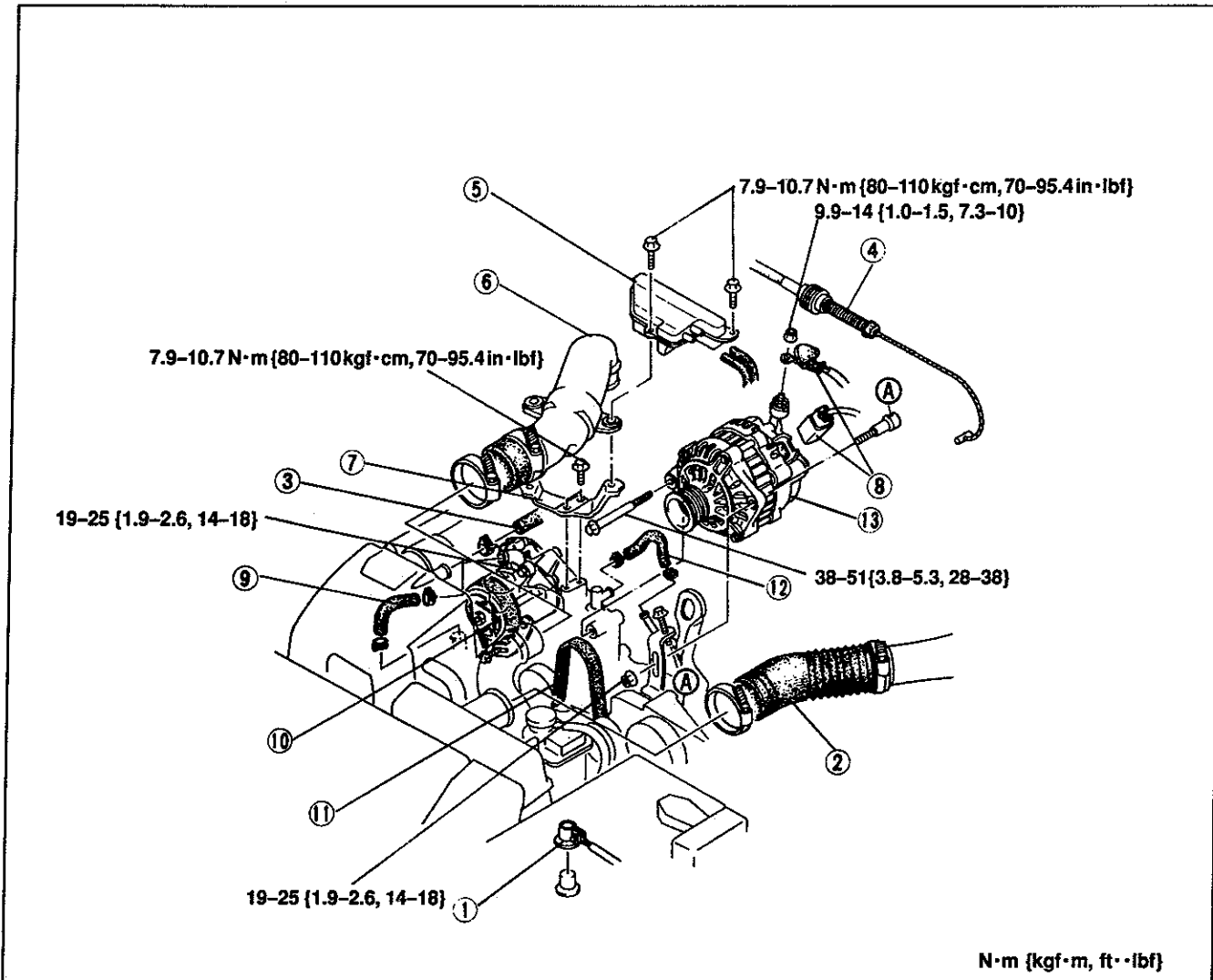

1. Battery negative cable
2. Air-intake hose
3. Air-relief hose
4. Accelerator cable
5. Pressure chamber
6. Air pipe

7. Bracket
8. Terminal B and connector
9. Air pump hose
10. Air pump
11. Drive belt

12. Water hose
13. Alternator

Disassembly / Assembly
 page G-13
 Inspection page G-14

Inspection page G-15
 Adjustment ... page G-15

Disassembly / Assembly

1. Disassemble in the order shown in the figure, referring to **Disassembly Note**.
2. Inspect all parts and repair or replace as necessary.
3. Assembly in the reverse order of disassembly, referring to **Assembly Note**.

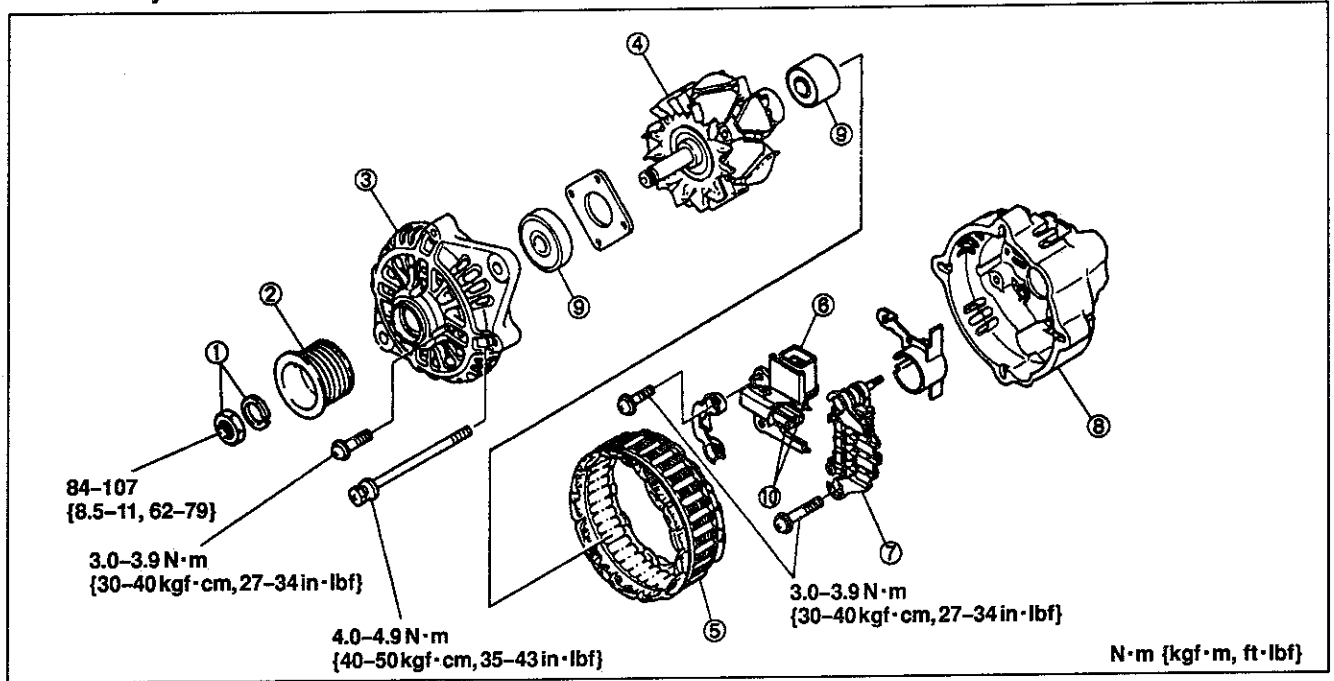

- | | | |
|---------------------------|---------------------------|---------------------------|
| 1. Nut, washer | 6. Regulator | 8. Rear bracket |
| 2. Pulley | Disassembly / Assembly | Disassembly / Assembly |
| 3. Front bracket | Note page G-13 | Note page G-13 |
| 4. Rotor | 7. Rectifier | 9. Bearing |
| Inspection page G-14 | Disassembly / Assembly | Inspection page G-14 |
| 5. Stator | Note page G-13 | 10. Brush |
| Disassembly / Assembly | Inspection page G-14 | Inspection page G-14 |
| Note page G-13 | | |
| Inspection page G-14 | | |

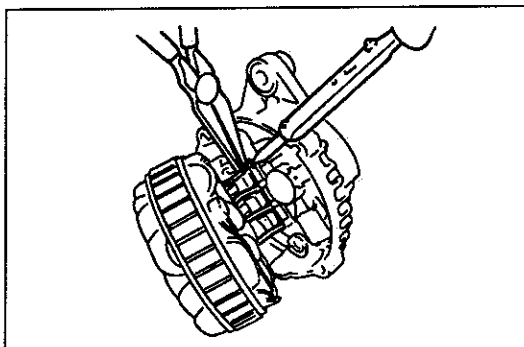

Disassembly / Assembly Note

Rear bracket, stator wire

Melt the solder quickly, the diodes (rectifier) and regulator will be damaged by excessive heat.

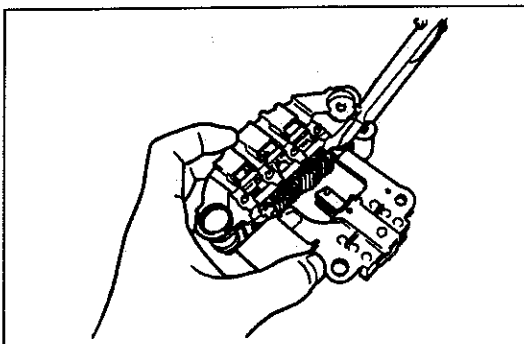

Brush holder, regulator assembly and rectifier

Melt the solder quickly, the diodes (rectifier) and regulator will be damaged by excessive heat.

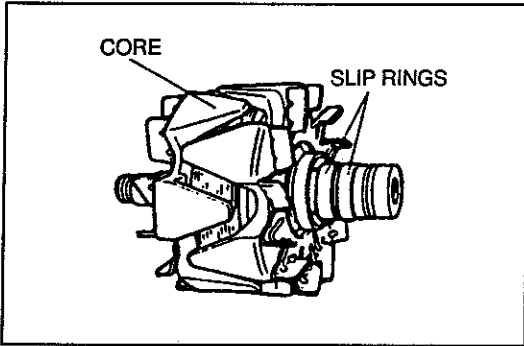

Inspection

Rotor

Check the continuity as shown.

Inspection point	Continuity
Core-Slip ring	No
Slip ring-Slip ring	Yes

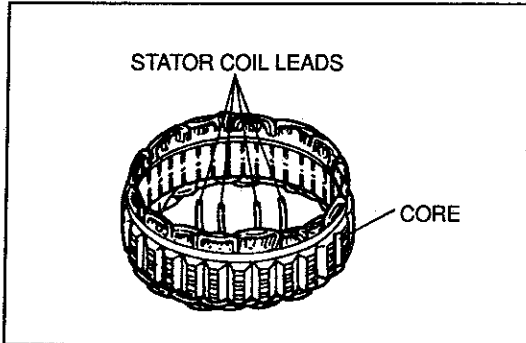

Stator

Check the continuity as shown.

Inspection point	Continuity
Core-Stator coil leads	No
Between leads	Yes

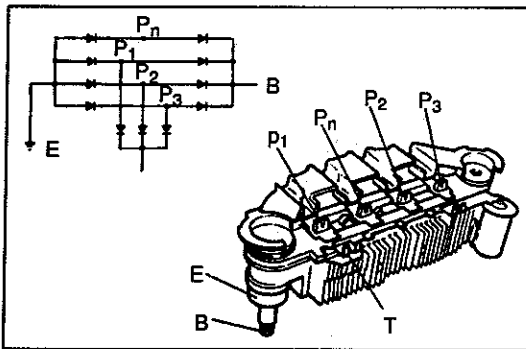

Rectifier

Check the continuity as shown.

Negative	Positive	Continuity
E	P _n , P ₁ , P ₂ , P ₃	Yes
B		No
T		No
P _n , P ₁ , P ₂ , P ₃	E	No
	B	Yes
P ₁ , P ₂ , P ₃	T	Yes
		No

Brush

If a brush is worn almost to or beyond the limit, replace the brushes.

Standard : 21.5 mm {0.846 in}

Minimum : 8.0 mm {0.32in}

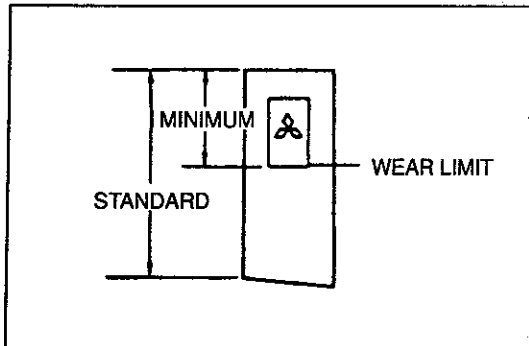

Bearing

1. Check for abnormal noise, looseness, and sticking.
2. Replace the bearing(s) as necessary.

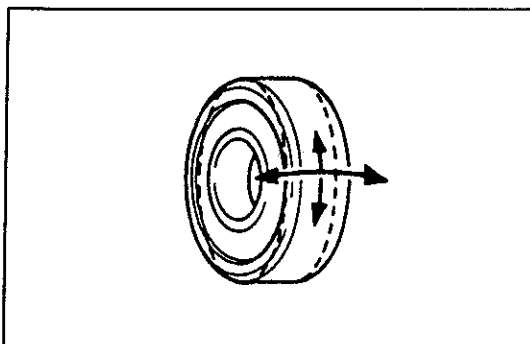

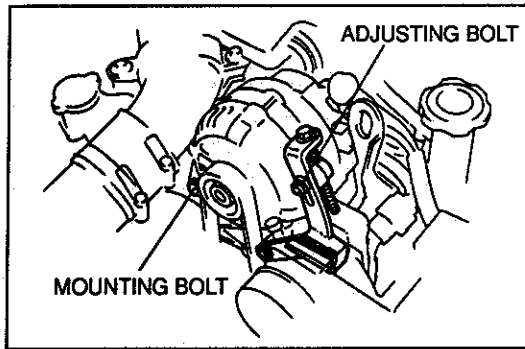
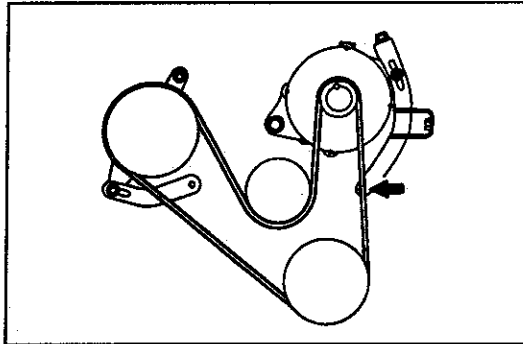
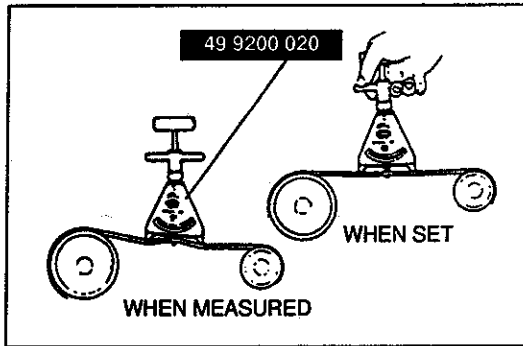

DRIVE BELT

Inspection

1. Check the drive belts and pulleys for wear, cracks and fraying. Replace as necessary.
2. Measure the drive belt tension by using a tension gauge, and measure the deflection by applying moderate pressure midway between the pulleys. Adjust the belt if necessary.

Specification Tension

Drive belt	N {kgf, lbf}		
	New	Used	Limit
Alternator	690-780 {70-80, 160-170}	590-680 {60-70, 140-150}	320 {33-73}

Deflection

Drive belt	mm {in}		
	New	Used	Limit
Alternator	6.0-7.0 {0.24-0.27}	7.0-7.5 {0.28-0.29}	9.0 {0.35}

Adjustment

1. Loosen the alternator mounting bolts and turn the adjusting bolt.
2. Move the alternator to set the specified deflection.
3. Tighten all bolts and recheck the tension.

Tightening torque:

Mounting bolt:

38-51 N·m {3.8-5.3 kgf·m, 28-38 ft·lbf}

Adjusting bolt:

19-25 N·m {1.9-2.6 kgf·m, 14-18 ft·lbf}

IGNITION SYSTEM

PREPARATION SST

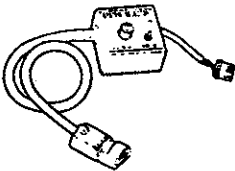
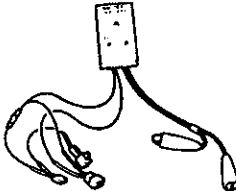
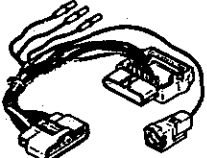
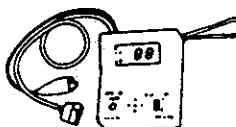
<p>49 B019 9A0 System selector</p> 	<p>For self-diagnosis and inspection of ignition timing</p>	<p>49 F018 002 Igniter Checker</p> 	<p>For inspection of igniter</p>
<p>49 F018 003 Adapter Harness</p> 	<p>For inspection of igniter</p>	<p>49 H018 9A1 Self-Diagnosis Checker</p> 	<p>For self-diagnosis inspection</p>

CIRCUIT DIAGRAM

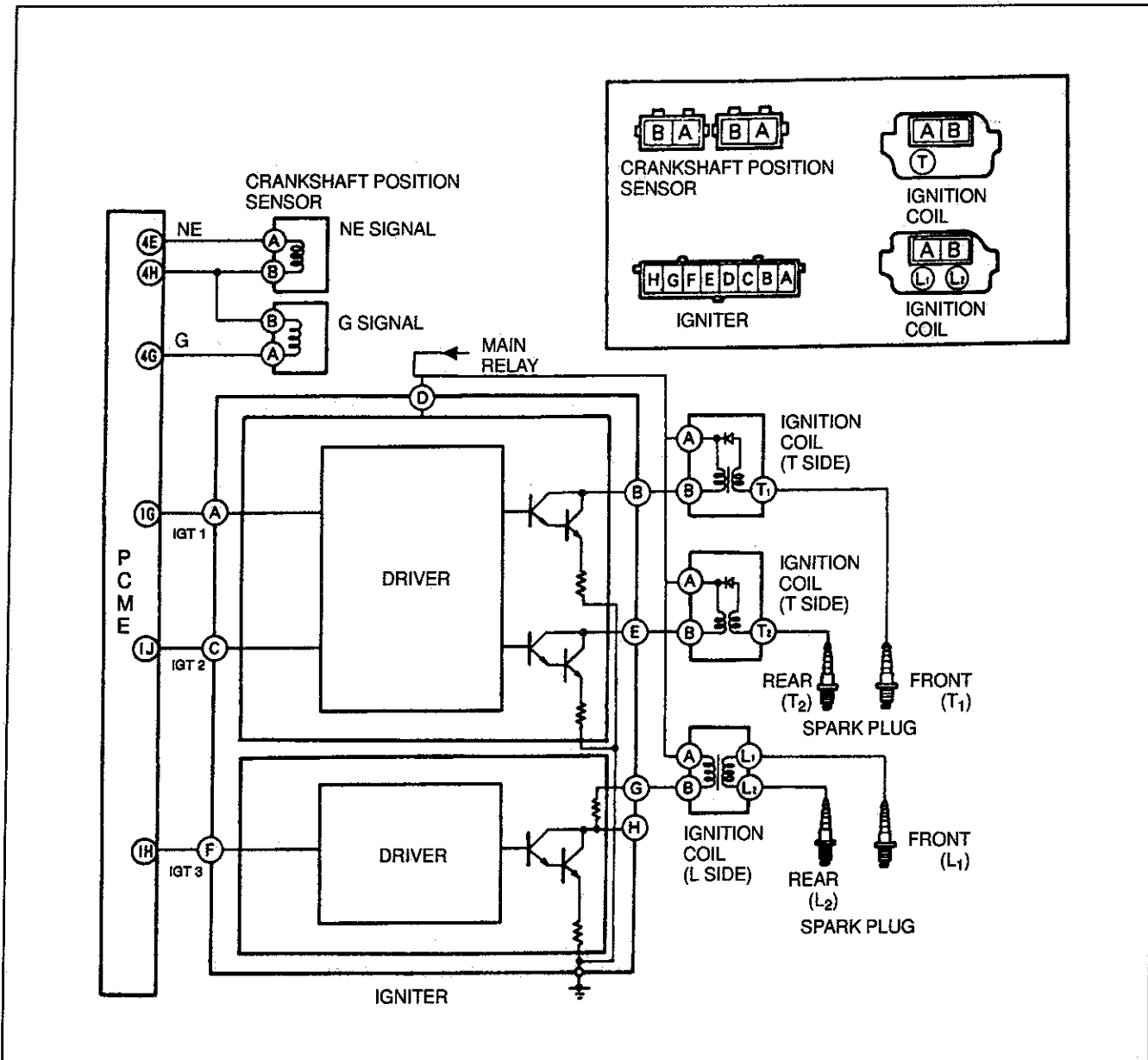

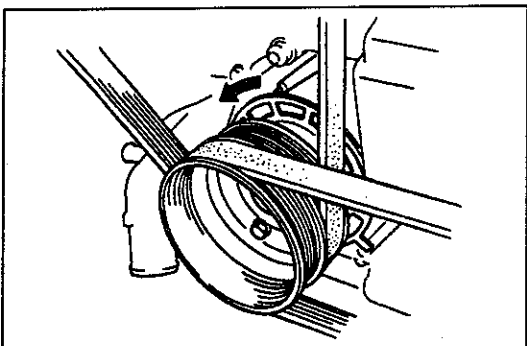
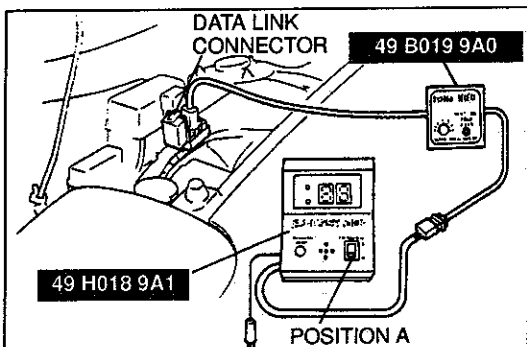
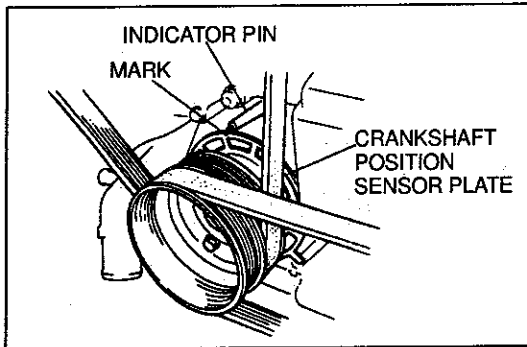
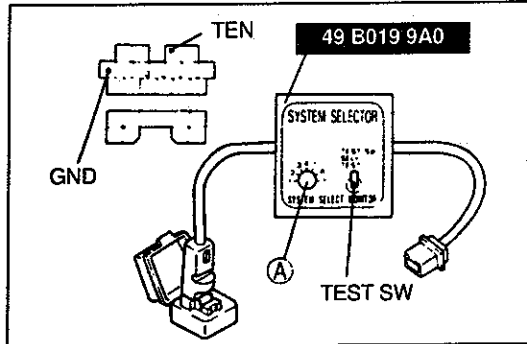
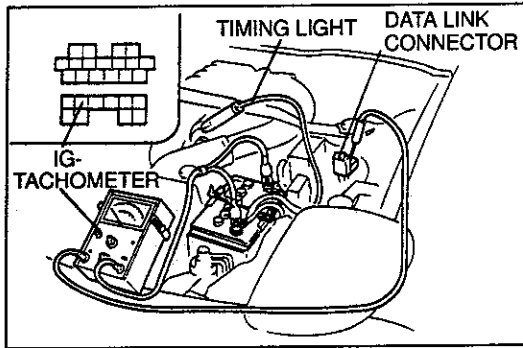

IGNITION TIMING

The ignition timing is set at the factory and must not be adjusted. Any adjustment will negatively effect the engine performance.

Preparation

1. Warm up the engine to normal operating temperature.
2. Run the engine at idle and verify the following.
 - Shift selector lever to P range (AT) / Neutral (MT).
 - Set steering wheel straight ahead.
 - Turn all electrical loads OFF.
 - Wait for electric coolant fan to stop.

Inspection

1. Connect a timing light to the high-tension lead of the front trailing side.
2. Connect a tachometer.

Note

- Some timing lights will not illuminate even if the ignition is working properly.

3. Connect the SST to the data link connector.
4. Set switch A to position 1.
5. Set TEST SW to SELF-TEST.
6. Verify that the idle speed is within specification.

Idle speed: 550–950 rpm

7. Verify that the timing mark (white) on the crankshaft position sensor plate is aligned with the indicator pin.

**Ignition timing: Trailing side: 20° ATDC (-20° BTDC)
Leading side: 5° ATDC (-5° BTDC)**

8. If the timing is incorrect, check the following.

- Verify that no diagnostic trouble code number is present. If present, check for the cause referring to the specified check sequence. (Refer to Section F)
- 05 Knock sensor
- 13 Manifold absolute pressure sensor

Input devices

- E/L, P/S, A/C, electric coolant fan
- Crankshaft position sensor (NE, G-Signal)
- Manifold absolute pressure sensor
- Throttle position sensor
- Neutral SW / Clutch SW (MT)
- Park/neutral signal (AT)

Others

- PCME terminal 3l voltage

8. Disconnect the SST.
9. Verify that the ignition timing advances when the engine is above 1,500 rpm.

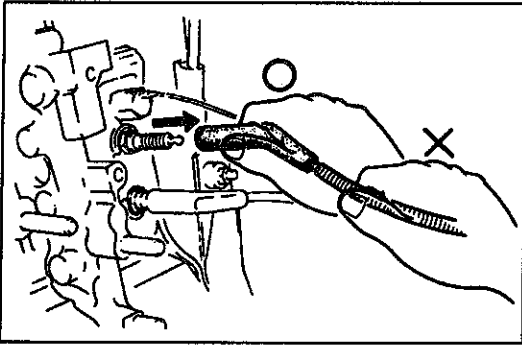

SPARK PLUGS

Removal / Installation

1. Remove and install the high-tension leads carefully.

Caution

- Pulling on the wire part of the spark plug lead may break it. To remove the lead, pull only on the boot.

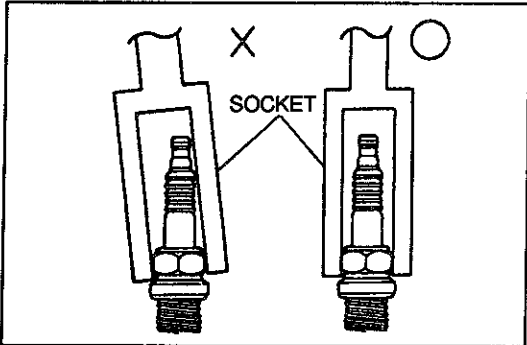

2. Remove and install the spark plugs by using a plug socket.

Caution

- To avoid breaking the spark plug, be sure to fit the socket squarely over it.

3. Apply anti-seize compound or molybdenum-based lubricant to the spark plug threads before installing.
4. Tighten the spark plugs to the specified torque.

Tightening torque:

13–17 N·m {1.3–1.8 kgf·m, 9.5–13 ft·lbf}

Spark test

1. Remove the spark plug.
2. Connect the spark plug to a high-tension lead.
3. Hold the high-tension lead and spark plug with insulated pliers 5–10 mm {0.20–0.39 in} from a ground.
4. Check the engine and verify that there is a strong blue spark.
5. Replace the spark plug or high tension lead as necessary if not as specified.

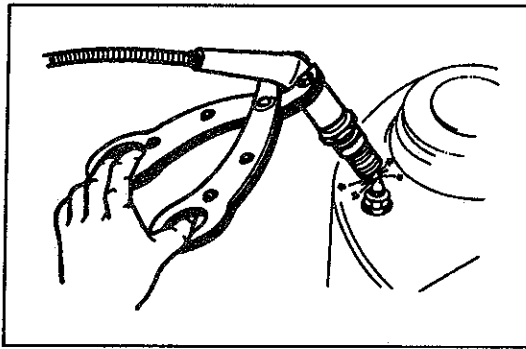

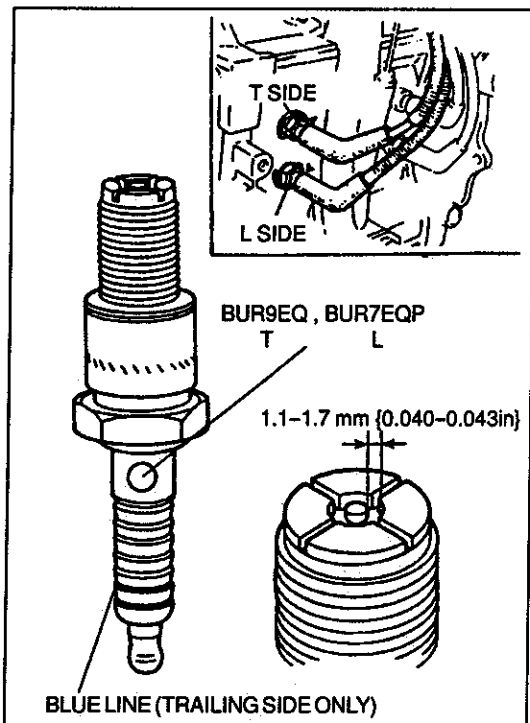

Inspection

Check the following points. If a problem is found, replace the spark plug.

- Damaged insulation
- Worn electrodes
- Carbon deposits

If cleaning is necessary, use a plug cleaner. Clean the upper insulator, also.

- Damaged gasket
- Burnt

Plug gap: 1.1–1.7 mm {0.044–0.066 in}

Plug position	NGK	Color
Leading side	BUR7EQP*, (BUR7EQ) (BUR6EQP) (BUR6EQ)	—
Trailing side	BUR9EQ*, (BUR9EQP) (BUR8EQP) (BUR8EQ)	Blue

* Standard plug

Caution

- The electrode is platinum coated. The following can scratch its platinum coating and impair its performance.

- (1) Adjusting the plug gap.
- (2) Using a wire brush to clean the electrode.
- (3) Using a plug cleaner for more than twenty (20) seconds, or at more than 588 kPa {6 kgf/cm², 85 psi}

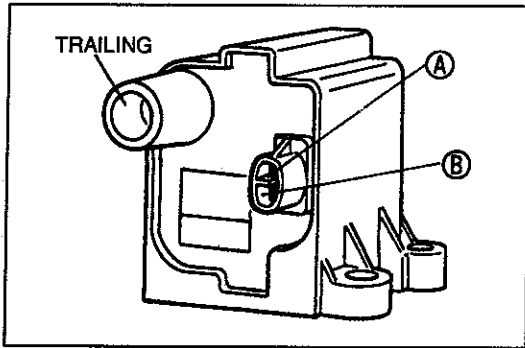

Inspection

T (Trailing) side

1. Measure resistance of the coil.

Inspection point	Resistance
A-B (primary coil winding)	below 1.0 Ω
A-T (secondary coil winding)	∞ (infinity)

2. If not within specification, replace the ignition coil.

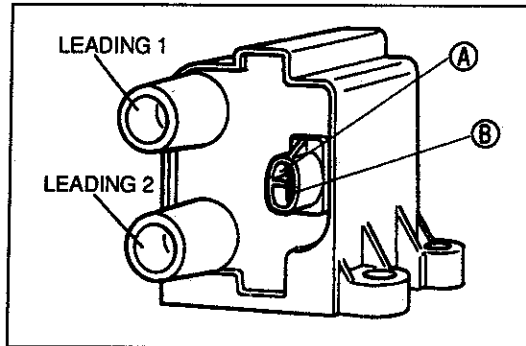

L (Leading) side

1. Measure resistance of the coil.

Inspection point	Resistance
A-B (primary coil winding)	below 1.0 Ω
L ₁ -L ₂ (secondary coil winding)	9.6-16.0 kΩ

2. If not within specification, replace the ignition coil.

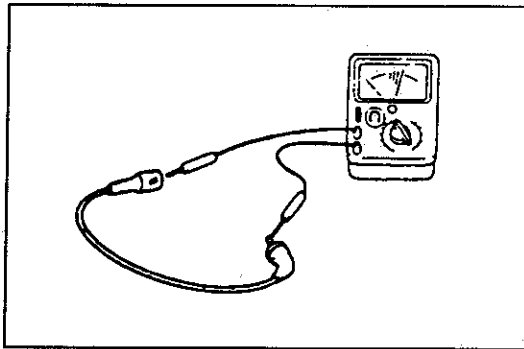

HIGH-TENSION LEAD

Removal / Installation

Caution

- Reinstall the high-tension leads to their original positions. Incorrect installation can damage the leads and cause power loss, and negatively effect electronic components.

Inspection

1. Measure resistance of the high-tension leads.

Specification: 16 kΩ per 1m {3.28 ft}

2. If not as specified, replace the high-tension leads.

IGNITER

Removal / Installation

1. Remove in the order shown in the figure.
2. Install in the reverse order of removal.

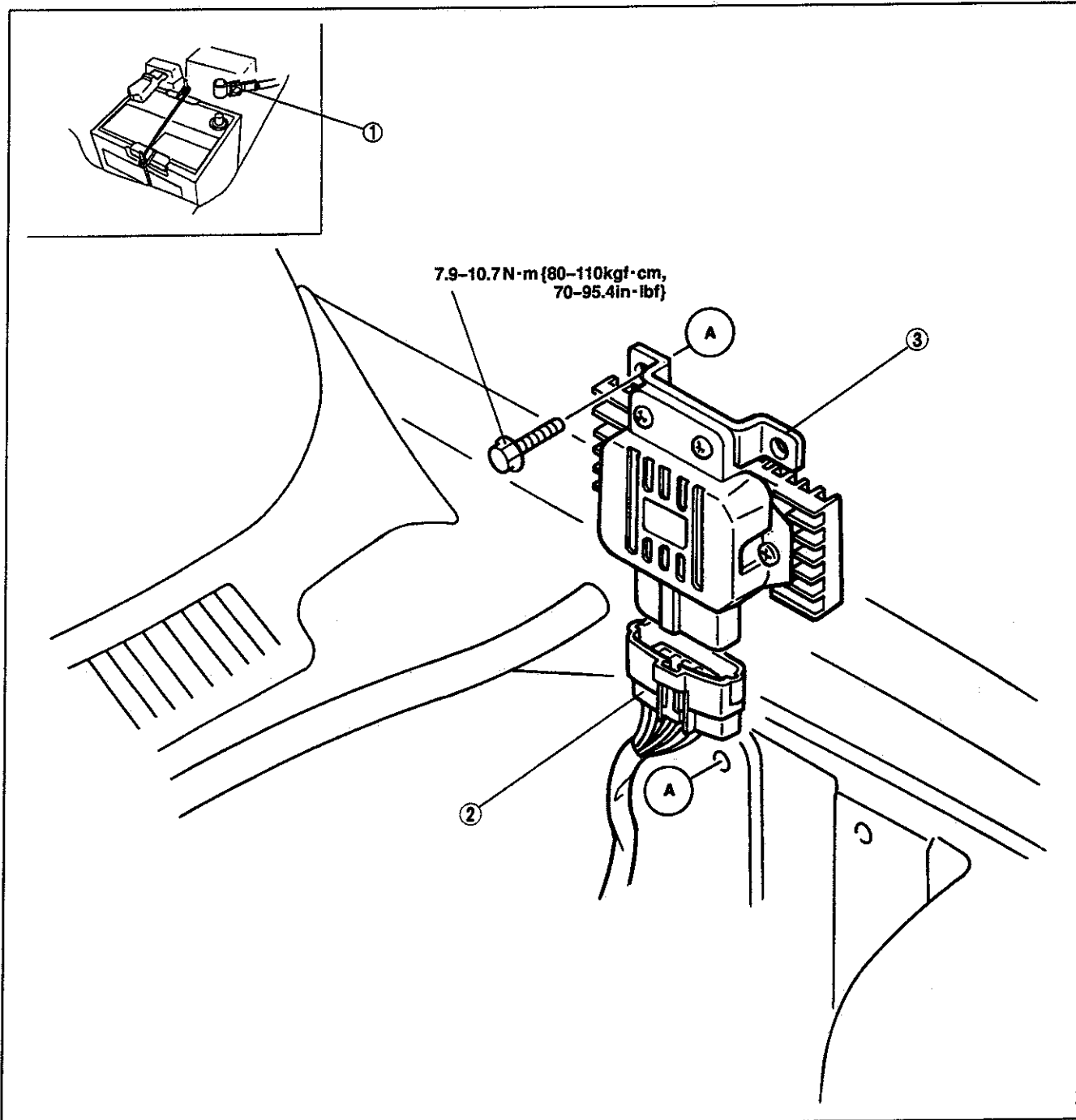

1. Battery negative cable
2. Connector

3. Igniter
Inspection page G-23

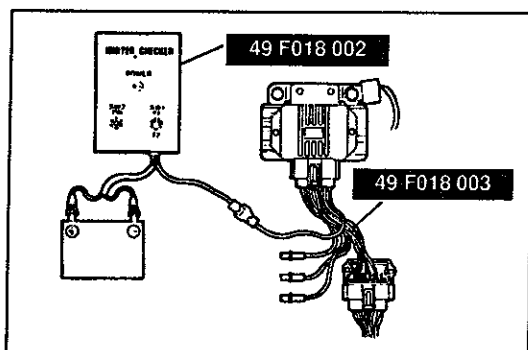

Inspection

Before this inspection, check the specific gravity of the battery, and that it is at or near full charge.

1. Disconnect the negative battery cable.
2. Disconnect the igniter connector.
3. Connect the **SST**.
4. Reconnect the negative battery cable.
5. Turn the ON ignition switch.

Note

- Switch 1 may be in either position.

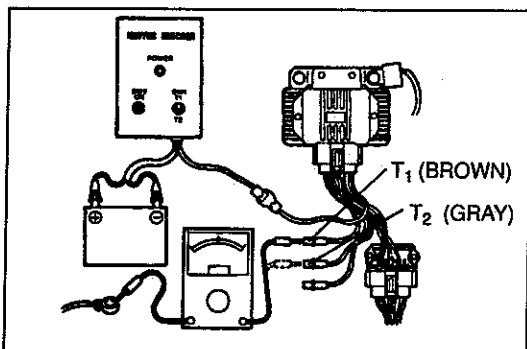
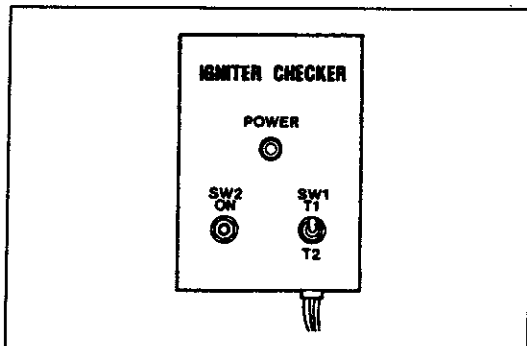

Trailing side

1. Insert the voltmeter probe into the brown (Front rotor trailing) or gray (Rear rotor trailing) lead of the **SST** (adapter harness) and verify that the voltage is as specified.

Voltage: Battery positive voltage

2. Press switch 2 to ON when certify to shake a hand of voltmeter.
3. Replace the igniter, if necessary.

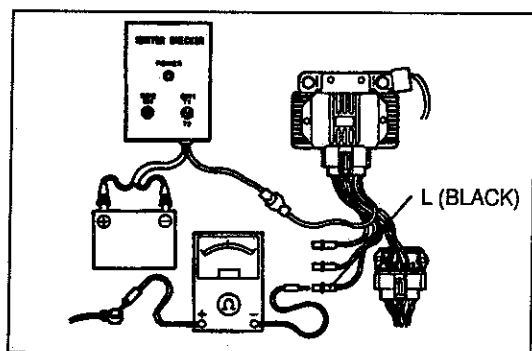

Leading side

1. Insert the voltmeter probe into the black lead of the **SST** (adapter harness) and verify that the voltage is as specified.

Voltage: Battery positive voltage

2. Press switch 2 to ON when certify to shake a hand of voltmeter.
3. Replace the igniter, if necessary.

STARTING SYSTEM

PREPARATION SST

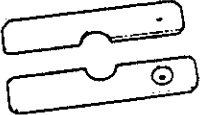
<p>49 E301 144 Plate, removing</p>		<p>For installation of overrunning clutch</p>
--	---	---

CIRCUIT DIAGRAM

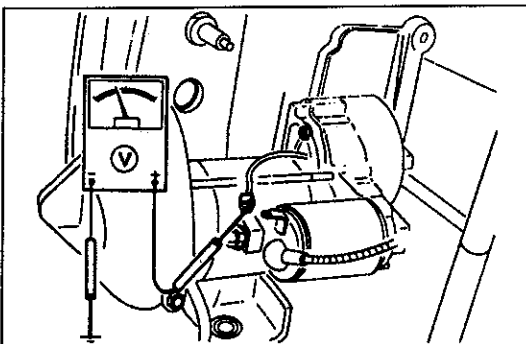
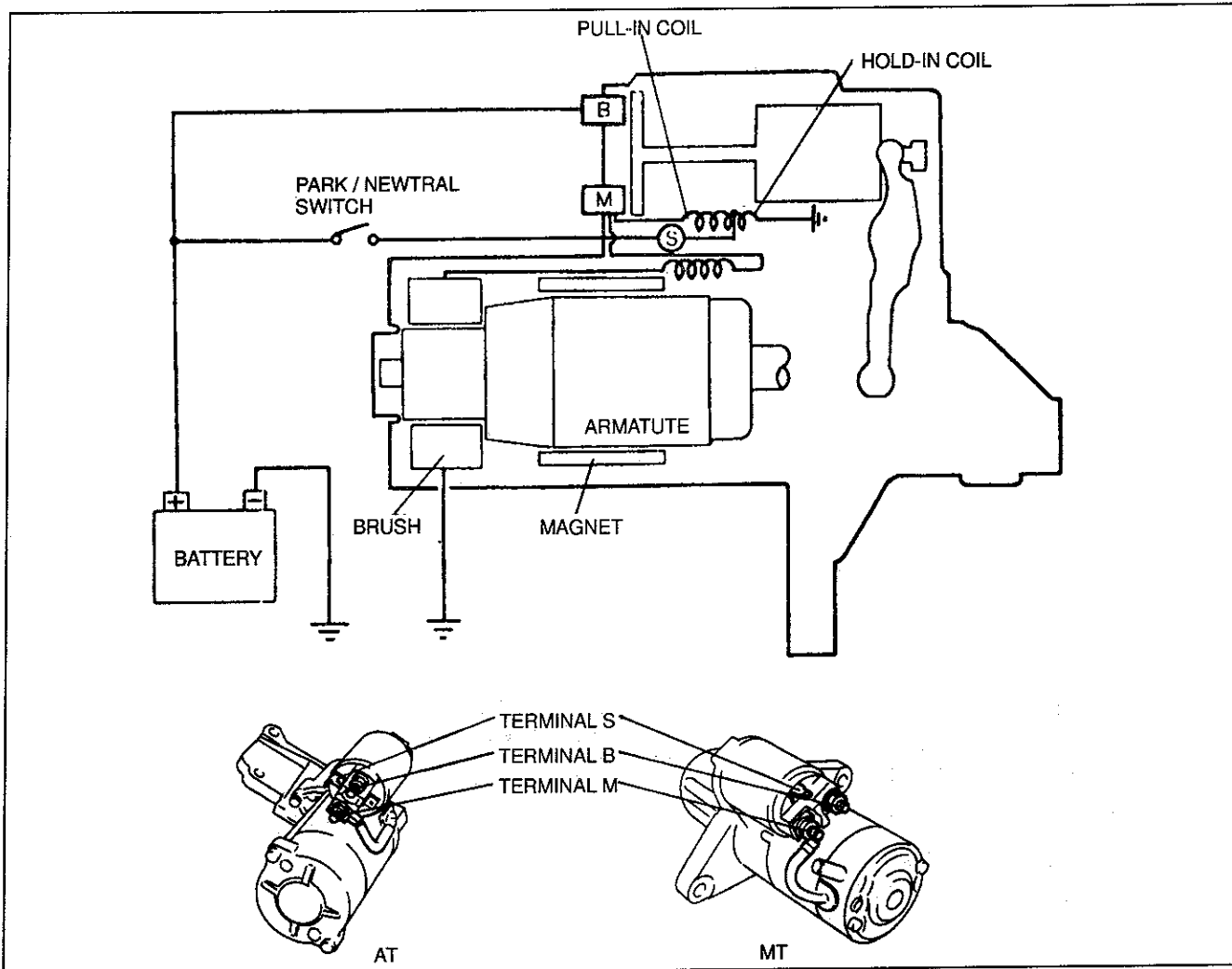

STARTER

Inspection (on-vehicle)

1. Measure the battery positive voltage.

Specification: Above 12.4V

2. Crank the engine, and verify that the starter turns smoothly.
3. If the starter does not turn, measure the voltage at terminal S.
4. If the voltage is **more than 8V**, remove and inspect the starter. If the voltage is **less than 8V**, check the wiring harness, ignition switch, and park/neutral switch (AT).

Removal / Installation

1. Remove in the order shown in the figure.
2. Inspect all parts and repair or replace as necessary.
3. Install in the reverse order of removal.

MT

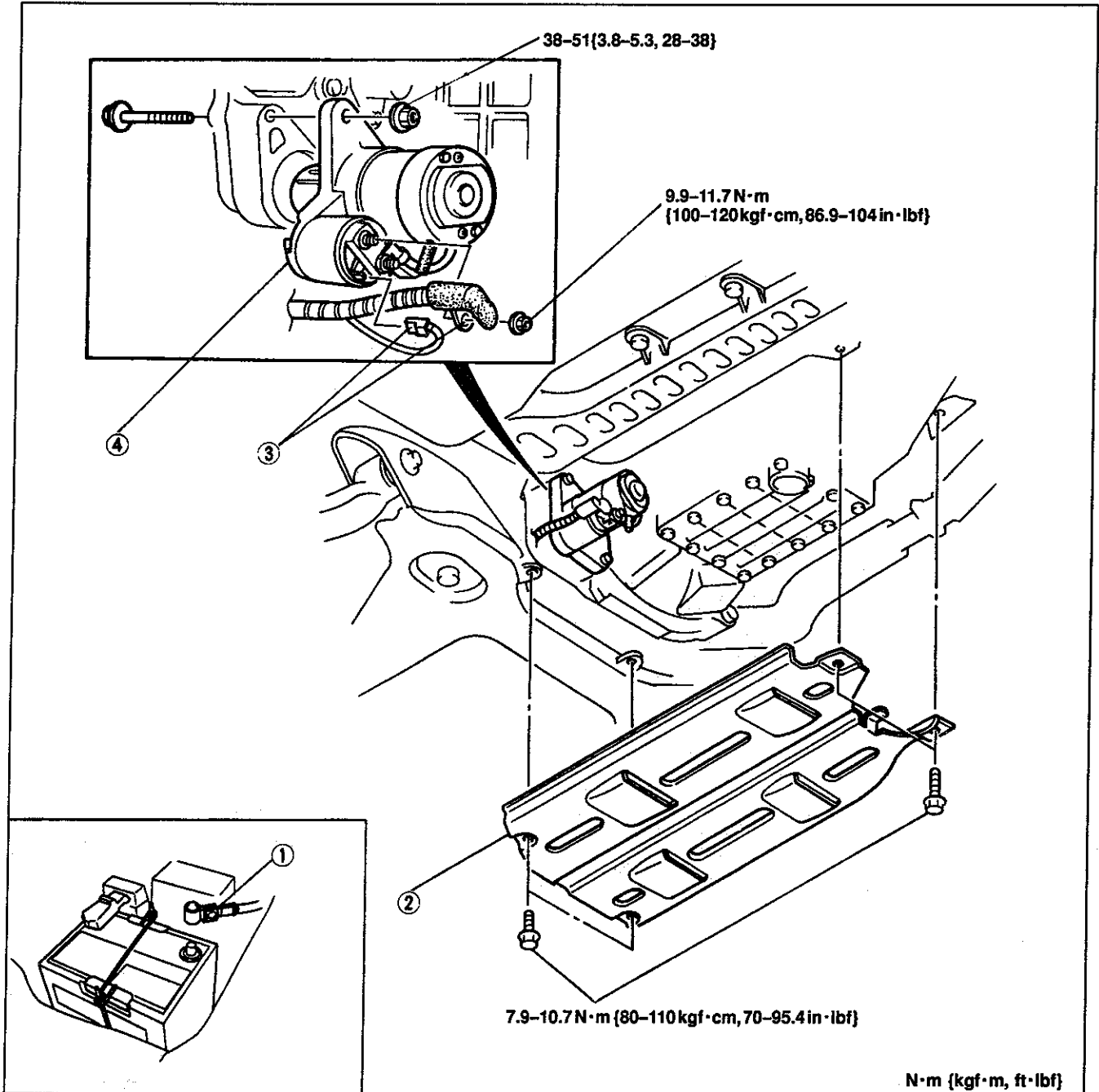

1. Battery negative cable
2. Under cover
3. Terminal S and B wire

4. Stator
 - Performance inspection page G-27
 - Disassembly / Assembly page G-28
 - Inspection page G-30

AT

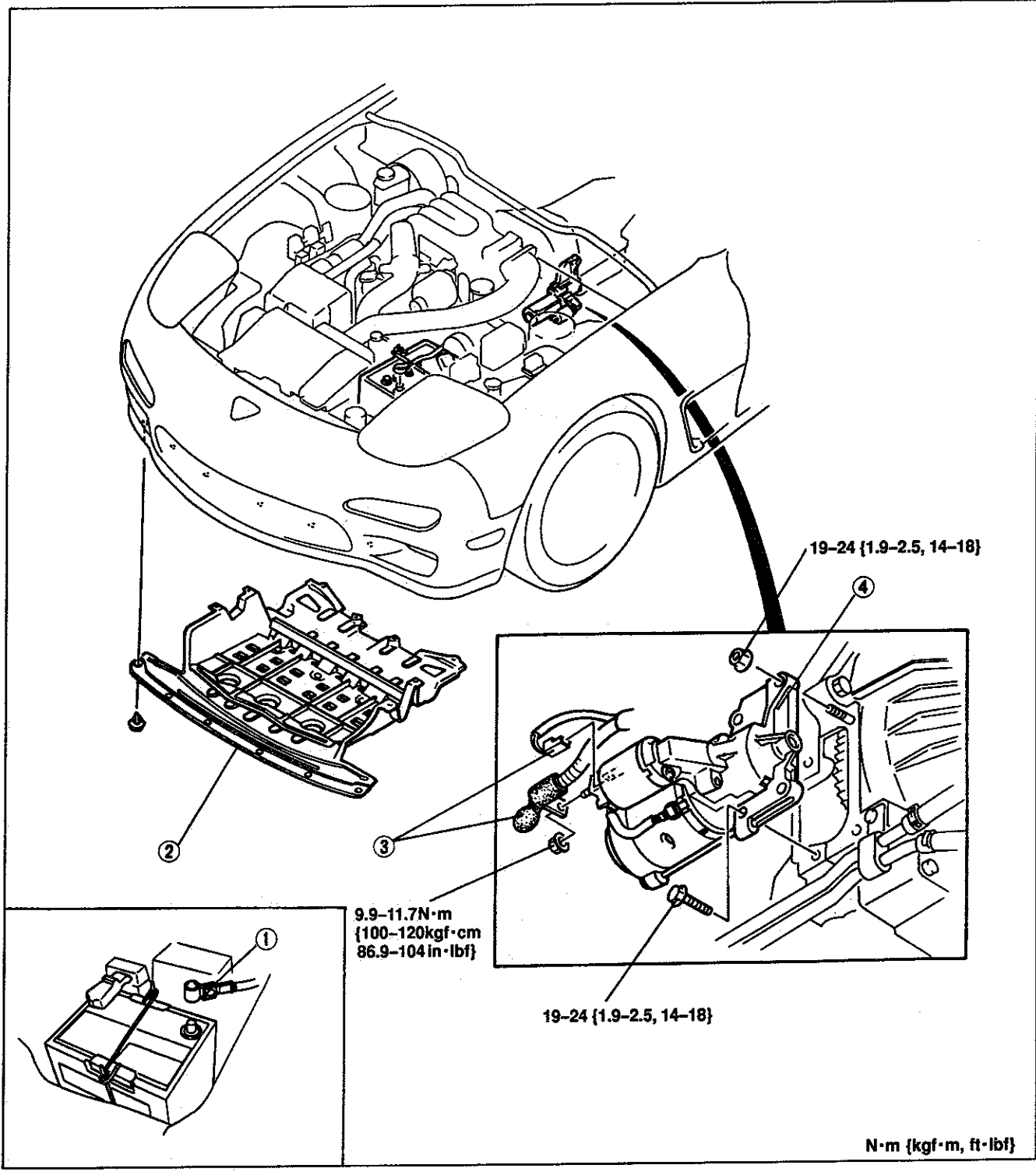

- 1. Battery negative cable
- 2. Under cover
- 3. Terminal S and B wire

- 4. Stator
 - Performance inspection page G-27
 - Disassembly / Assembly page G-29
 - Inspection page G-30

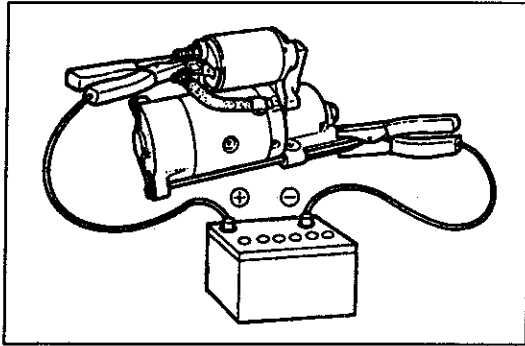

Performance Inspection

Magnetic switch

Disconnect terminal M wire, and perform the following tests. Replace the magnetic switch if necessary.

Pull-in test

Connect battery positive voltage as shown and verify that the pinion is ejected.

Caution

- Applying power for more than 10 seconds can damage the starter.

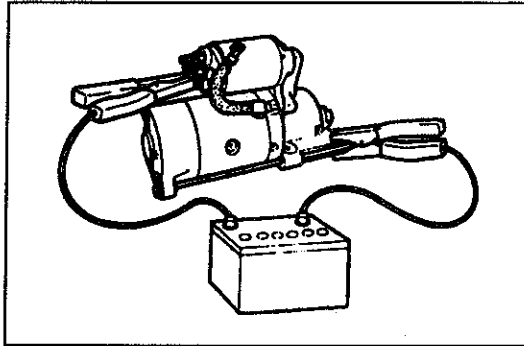

Hold-in test

After completing the pull-in test, disconnect the wire from terminal M (with pinion ejected) and verify that the pinion does not return.

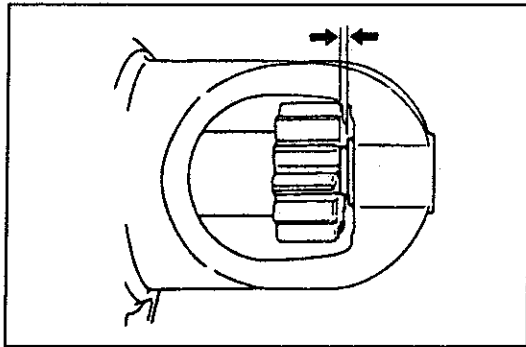

Adjustment of pinion gap

1. Disconnect the wire from terminal M.
2. Apply battery positive voltage between terminal S and the starter body.
3. Measure the clearance (pinion gap) between the pinion and the stopper.

Caution

- Applying power for more than 10 seconds can damage the starter.

Pinion gap: 0.5–2.0 mm {0.020–0.078 in}

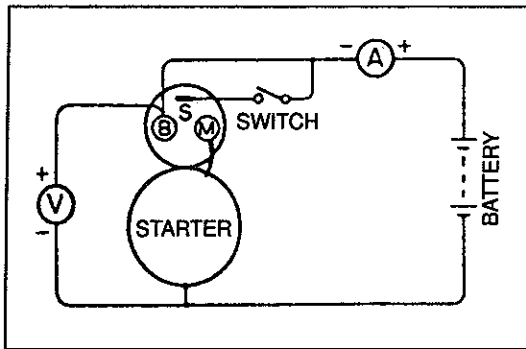

4. If the pinion gap is not within specification, increase or decrease the number of washers between the magnetic switch and the drive housing.

Note

- The gap becomes smaller as the number of washers is increased.

No load test

1. Connect a circuit as shown.
2. Measure voltage, current, and speed as shown below.

Voltage	(V)	11.0
Current	(A)	Max 90
Speed	(rpm)	Min 2,200 (AT), Min 3,000 (MT)

Disassembly / Assembly

1. Disassemble in the order shown in the figure.
2. Inspect all parts and repair or replace as necessary.
3. Assemble in the reverse order of disassembly.

MT

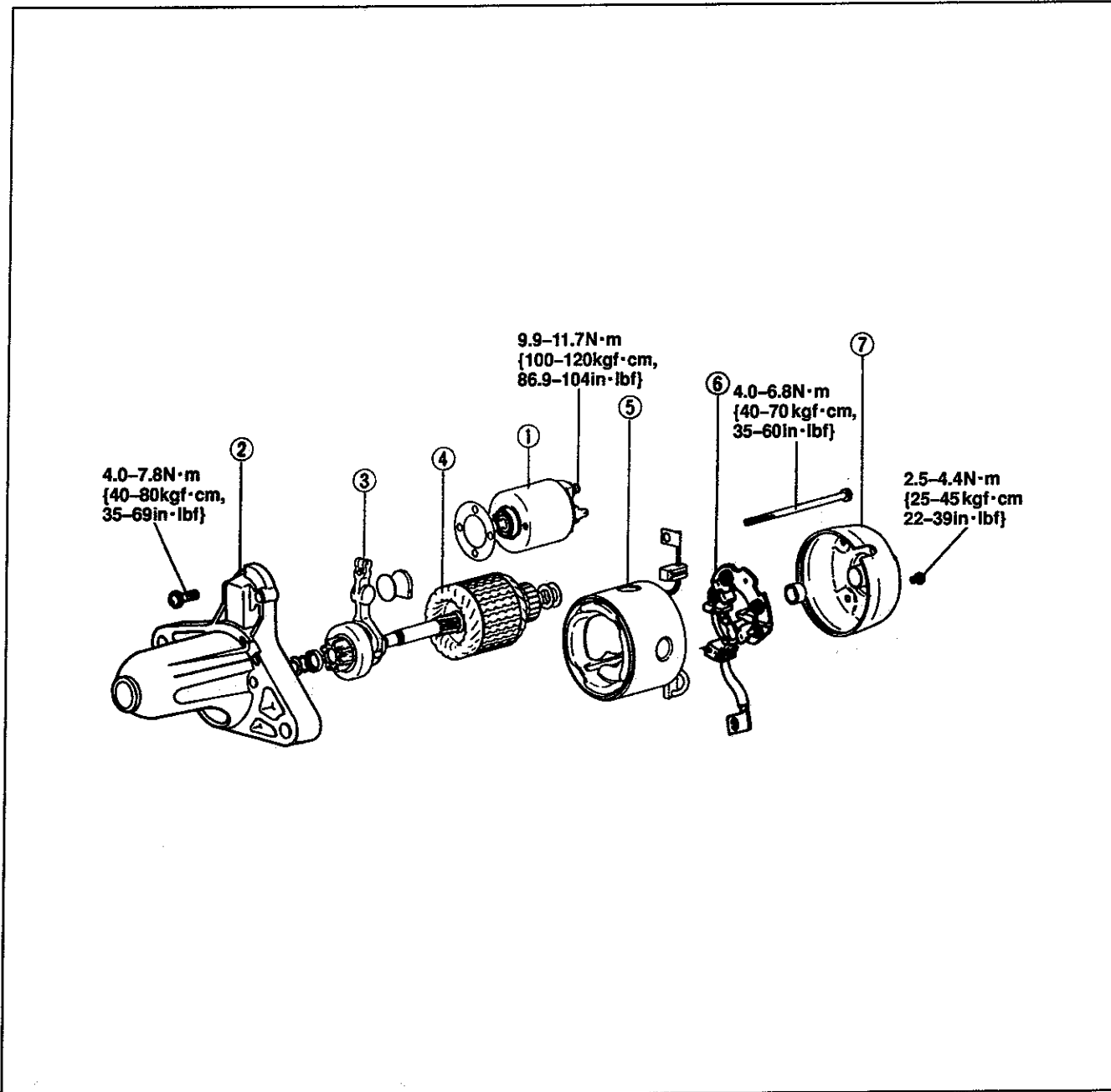

- 1. Magnetic switch
 - Performance inspection page G-27
 - Inspection page G-30
- 2. Front bracket
- 3. Drive pinion
 - Inspection page G-31

- 4. Armature
 - Inspection page G-30
- 5. Field coil
 - Inspection page G-30
- 6. Brush and Brush holder
 - Inspection page G-31
- 7. Rear bracket

AT

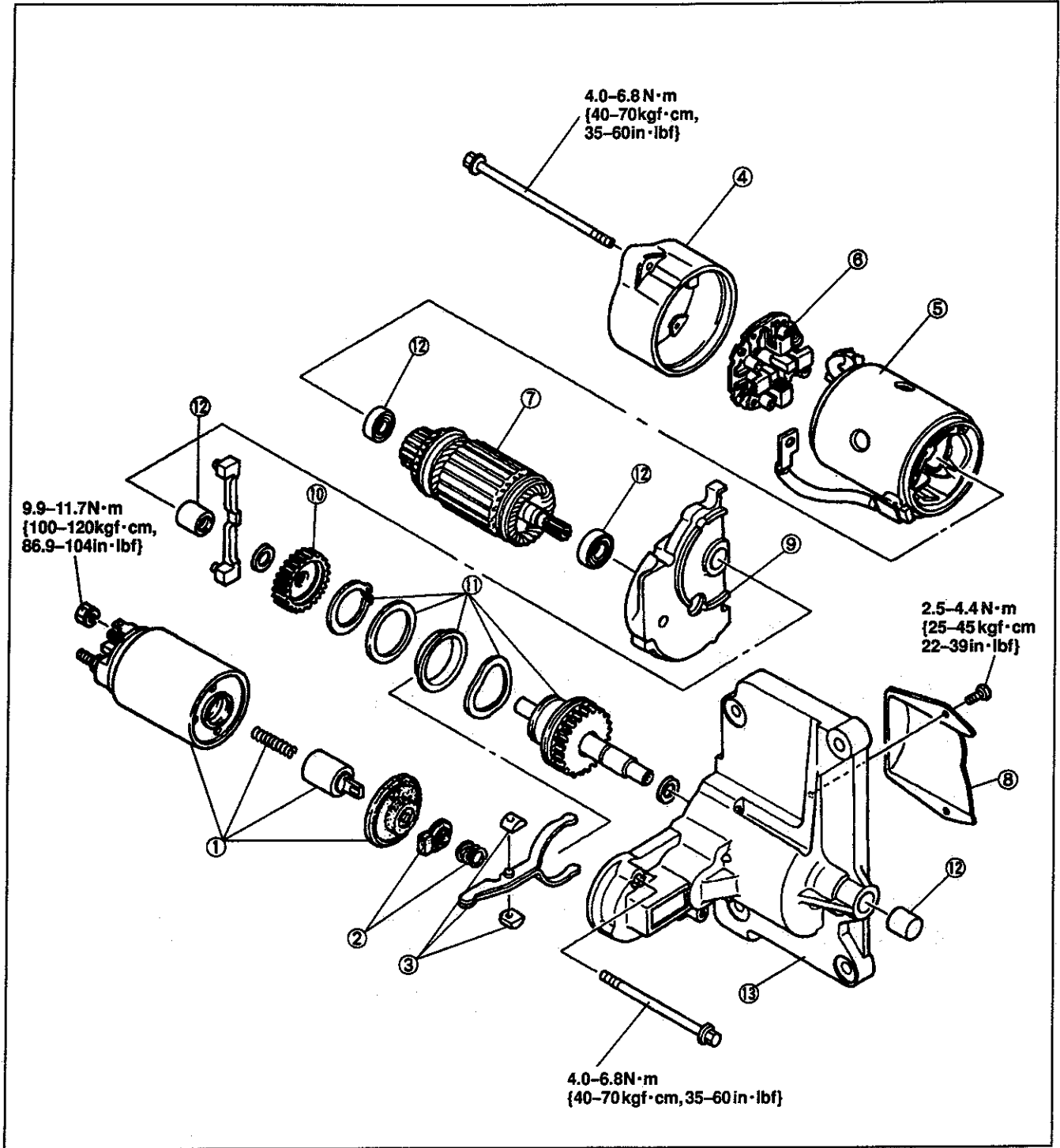

- | | | |
|---|--|--|
| 1. Magnetic switch
Performance
Inspection page G-27
Inspection page G-30 | 5. Field coil
Inspection page G-30 | 9. Center bracket |
| 2. Spring set | 6. Brush and Brush holder
Inspection page G-31 | 10. Reduction gear |
| 3. Lever set | 7. Armature
Inspection page G-30 | 11. Pinion shaft assembly
(Overrunning clutch)
Inspection page G-31 |
| 4. Rear bracket | 8. Cover | 12. Bearing |
| | | 13. Front bracket |

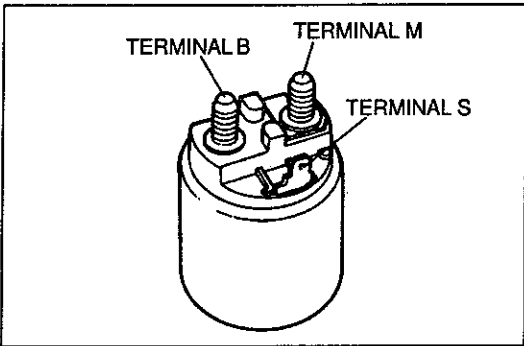

Inspection

Magnetic switch

Check the continuity as shown.

Inspection point	Continuity
Terminal S-M	Yes
Terminal M-B	No
Terminal S-Body	Yes

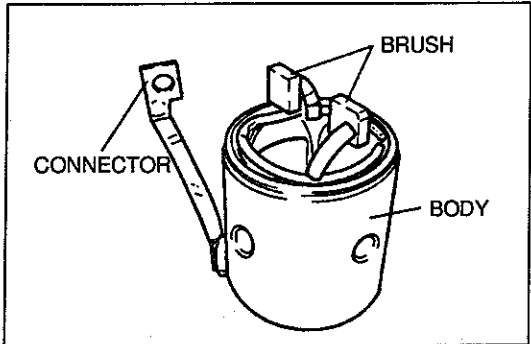

Field coil

Check the continuity as shown.

Inspection point	Continuity
Brush - Connector	Yes
Body - Connector	No

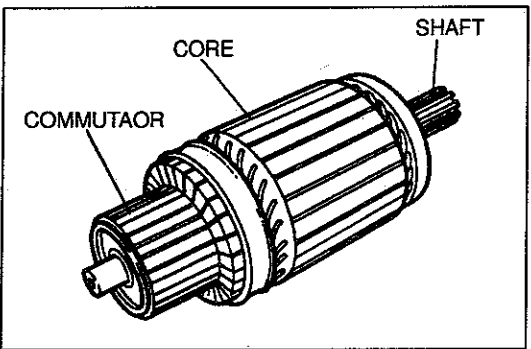

Armature

1. Check the continuity as shown.

Inspection point	Continuity
Commutator - Core	Yes
Commutator - Shaft	No
Core - Shaft	No

2. Replace the armature if the outer diameter of the commutator is almost at or less than the minimum.
3. If the commutator surface is dirty, wipe it with a cloth; if it is rough, repair it with a lathe or fine sandpaper.

Minimum diameter
32.0 mm {1.26 in}

4. Place the armature on V-blocks, and measure the runout by using a dial indicator.
5. If the runout is not within specification, repair the armature by using a lathe or replace it.

Runout: 0.05 mm {0.002 in}

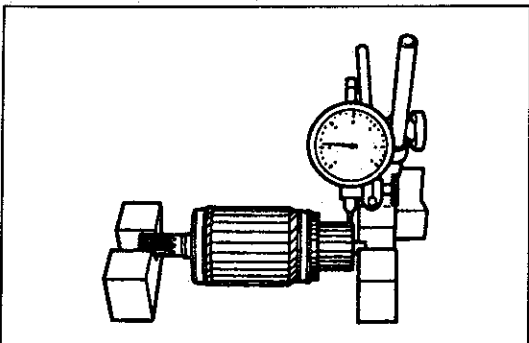
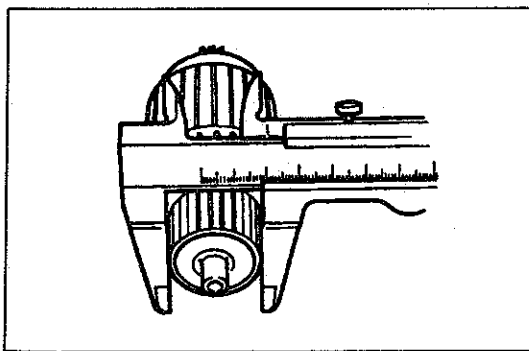

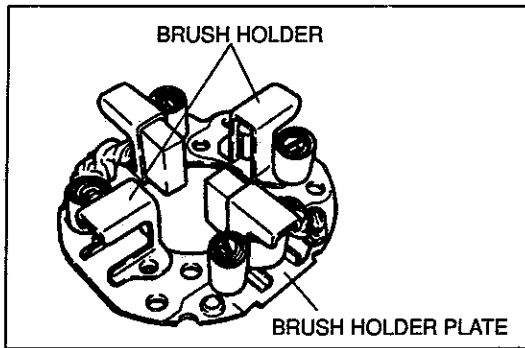

Brush and Brush holder

1. Check for continuity between the insulated brush and the plate. Repair or replace if there is continuity. Also check that the brush slides smoothly inside the brush holder.

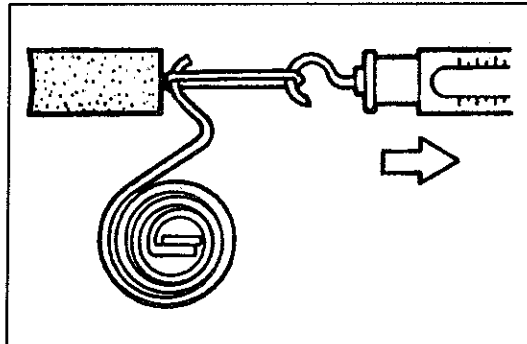

2. Measure the force of the brush spring by using a spring balance.

Standard: 18.6–22.6 N {1.89–2.31 kgf, 4.16–5.08 lbf}
Maximum: 6.9 N {0.7 kgf, 1.5 lbf}

3. Replace the spring if not as specified.

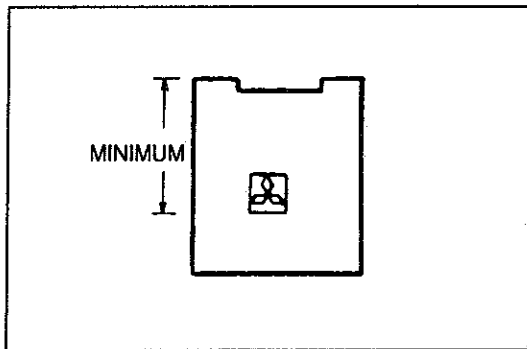

4. If a brush is worn almost to or beyond the wear limit, replace all of the brushes.

Specification		MT	AT
Standard	mm {in}	17 {0.67}	18 {0.71}
Minimum	mm {in}	11 {0.43}	11 {0.43}

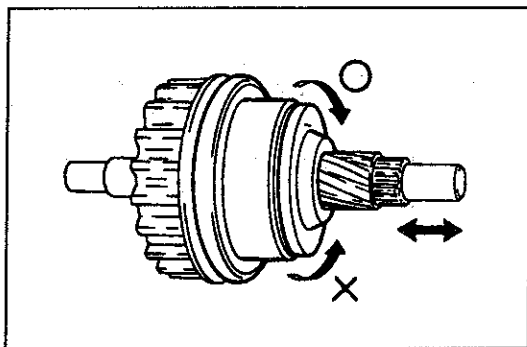

Overrunning Clutch

1. Turn the pinion shaft by hand while holding the overrunning clutch.
2. Replace the overrunning clutch if the pinion turns in both or in neither direction.

Caution

- Using cleaning fluids or a steam cleaner to clean the overrunning clutch can dissolve the grease inside it.

INTERLOCK SWITCH

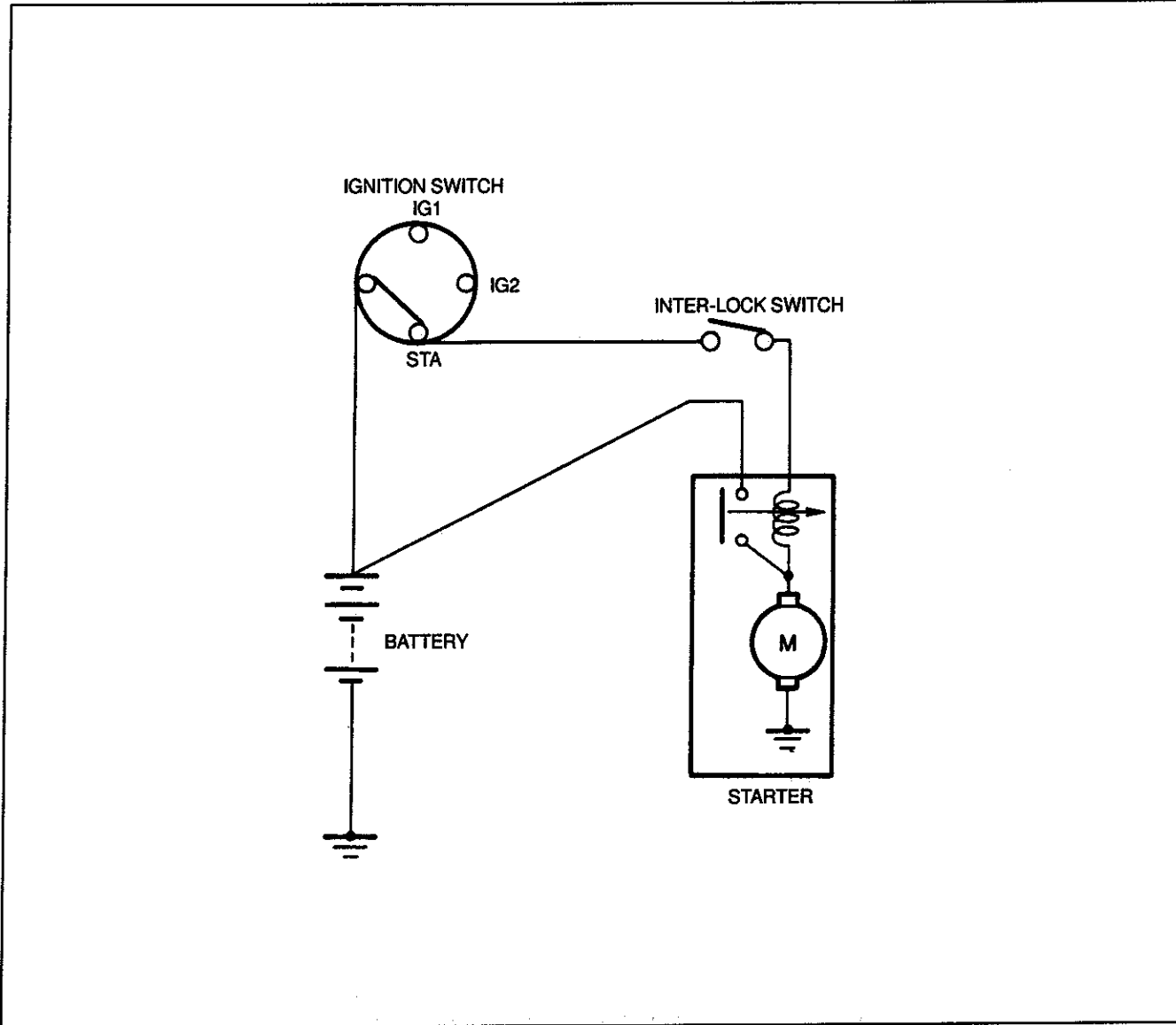

This system is similar to that of the park/neutral switch on at AT vehicle. If the clutch pedal is not depressed during starting, battery power will not be supplied to the starter and the starter will not operate.

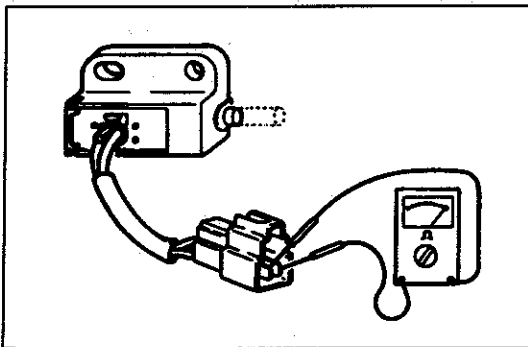

Inspection

1. Disconnect the interlock switch connector.
2. Connect a circuit tester to the switch.
3. Check the continuity.

Pedal	Continuity
Depressed	Yes
Released	No

4. If not as specified, replace the switch.